

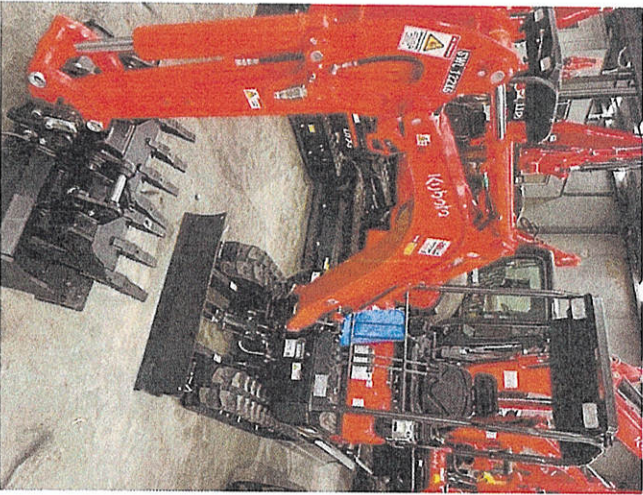

2617

This form is to be completed in accordance with the Hazard Management Policy/Procedure and Plant and Equipment Safety Management Policy/Procedure.
For further information please refer to the OHS Regulations Part 3 Plant

Overall risk rating
(existing controls)
highest score
eg L, M, H, VH

M

STEP 1 : ENTER INFORMATION ABOUT THE ITEM OF PLANT/EQUIPMENT, ITS LOCATION AND THE PEOPLE COMPLETING THE RISK ASSESSMENT			
Plant Location:	HALLAM	Owner of Plant:	S & S EQUIPMENT HIRE AND SALES
Plant: (Include name and model)	KUBOTA U17-3HG EXCAVATOR		
Purpose of Plant:	CIVIL CONSTRUCTION		
Current Photo of machine being assessed.	REGISTRATION/LICENCES/COMPETENCIES (Refer Appendix B)	LEGISLATION	RISK ASSESSMENT TEAM
	<p>Registration required? <input type="checkbox"/> Yes <input checked="" type="checkbox"/> No</p> <p>Licence/ Trade certificate required? <input type="checkbox"/> Yes <input checked="" type="checkbox"/> No</p> <p>Supervisor assessment required? (Induction required for this plant) <input type="checkbox"/> Yes <input checked="" type="checkbox"/> No</p> <p>Other competency required? <input checked="" type="checkbox"/> Yes <input type="checkbox"/> No</p> <p>Include in Safe Operating Procedure <input type="checkbox"/></p>	<p>OHS Legislation and/or Australian Standard to be used for further reference.</p> <p>OHS Regulations (2017) Divisions:</p> <ul style="list-style-type: none"> ▪ 1.2 OHS Responsibilities ▪ 1.3 Information, Instruction, Training, Induction, Supervision ▪ 2.10 Noise ▪ Part 3 Plant (including) <ul style="list-style-type: none"> ▪ 3.2.25 Plant with moving parts ▪ 3.2.15 Hazard Management ▪ 3.2.17 Control of risk ▪ AS 4024 - 2014 Safety of machinery ▪ AS 1788 Abrasive wheels ▪ AS 60204. 1 electrical equipment for industrial machines 	<p>Operator:</p> <p>HSO/Manager:</p> <p>HSR:</p> <p>Assessor: CARL HAWORTH</p> <p>Consultant: AIDEN BRAND-OLIVER</p> <p>Date Assessed: 2/03/2023</p> <p></p> <p>CARL HAWORTH</p>
		SERIAL NO: 56877 HOURS: 1.2	Date assessed: 2/03/2023 Review date: 2/03/2024 (1 yr, from RISK ASSESSMENT)
(Signature)	(Name)		

LEGEND	
<input type="checkbox"/> EI = Elimination	<input type="checkbox"/> Is = Isolation
<input type="checkbox"/> Su = Substitution	<input type="checkbox"/> Ad = Administration
<input type="checkbox"/> En = Engineering	<input type="checkbox"/> PPE = Personal Protective Equipment

Hazard Identified	Likelihood	Consequence	Score	Comments (ie when and where hazard is present, task/activity)	Hierarchy of control	Current Controls	Action required Y/N
Can the following items become entangled (eg in moving parts)?							
<input checked="" type="checkbox"/> Yes (e.g. Hair, Jewellery, Clothing, Cleaning aids (cloth), Gloves or Other _____)	UNLIKELY	FIRST AID	MEDIUM	When in operation, pedestrians to keep clear	<input checked="" type="checkbox"/> EI <input type="checkbox"/> Su <input type="checkbox"/> En <input type="checkbox"/> Is <input checked="" type="checkbox"/> Ad <input checked="" type="checkbox"/> PPE	Warning decals in place. Guards are installed. Engine covers are fitted. Induction.	N
<input type="checkbox"/> No <input type="checkbox"/> NA							
Are emergency stop buttons adequate?							
<input checked="" type="checkbox"/> Yes (within easy reach and clearly marked) <input type="checkbox"/> No <input type="checkbox"/> Other issues _____ <input type="checkbox"/> NA					<input type="checkbox"/> EI <input type="checkbox"/> Su <input type="checkbox"/> En <input type="checkbox"/> Is <input type="checkbox"/> Ad <input type="checkbox"/> PPE	Customer to organise installation of any others if required.	N
Are there adequate fire extinguishers fitted?							
NO							N
Is there a working travel alarm fitted?							
Yes.							N
Is there a working flashing beacon?							
Yes.							N

LEGEND	
<input type="checkbox"/> E = Elimination	<input type="checkbox"/> Is = Isolation
<input type="checkbox"/> Su = Substitution	<input type="checkbox"/> Ad = Administration
<input type="checkbox"/> En = Engineering	<input type="checkbox"/> PPE = Personal Protective Equipment

Hazard Identified	Likelihood	Consequence	Score	Comments (ie when and where hazard is present, task/activity)	Hierarchy of control	Current Controls	Action required Y/N
<input checked="" type="checkbox"/> Plant falling or unexpected movement of the plant eg <input checked="" type="checkbox"/> Tipping <input checked="" type="checkbox"/> Falling <input checked="" type="checkbox"/> Rolling over <input checked="" type="checkbox"/> Rolling forward <input type="checkbox"/> The plant's load <input checked="" type="checkbox"/> Underbetween plant and a structure eg wall <input type="checkbox"/> Inability to apply brake <input checked="" type="checkbox"/> Falling off the plant <input checked="" type="checkbox"/> Part of the plant collapsing/changing shape <input type="checkbox"/> Other issues _____ <input type="checkbox"/> No <input type="checkbox"/> NA	UNLIKELY	MAJOR	MEDIUM	Unstable ground. Unexpected movement. Working near structures. Sudden reversing. Operator not wearing seatbelt. Working near pedestrians. Working on plant during maintenance and servicing.	<input checked="" type="checkbox"/> E <input type="checkbox"/> Su <input type="checkbox"/> En <input checked="" type="checkbox"/> Is <input checked="" type="checkbox"/> Ad <input checked="" type="checkbox"/> PPE	Neutral start switch fitted. Travel alarm and beacon fitted. Pedals are non-slip. Warning decals fitted. Park brake operational. Control pod operational. ROPS/FOPS structure fitted. Seatbelt fitted. Handrails fitted. SWL decals fitted. Do not lift above personnel decal fitted. Induction.	N
Can anyone be cut, stabbed or punctured, amputated by coming into contact with :							
<input checked="" type="checkbox"/> Moving plant or parts <input type="checkbox"/> Sharp or flying objects <input checked="" type="checkbox"/> Work pieces ejected <input type="checkbox"/> Work pieces disintegrating <input type="checkbox"/> Other issues _____ <input type="checkbox"/> No <input type="checkbox"/> NA	UNLIKELY	MAJOR	MEDIUM	Pedestrians to keep clear 30 metres. Quick hitch failure. Moving blade or bucket.	<input checked="" type="checkbox"/> E <input type="checkbox"/> Su <input type="checkbox"/> En <input checked="" type="checkbox"/> Is <input checked="" type="checkbox"/> Ad <input checked="" type="checkbox"/> PPE	Warning decals fitted. Induction.	N

LEGEND	
<input type="checkbox"/> EI = Elimination	<input type="checkbox"/> Is = Isolation
<input type="checkbox"/> Su = Substitution	<input type="checkbox"/> Ad = Administration
<input type="checkbox"/> En = Engineering	<input type="checkbox"/> PPE = Personal Protective Equipment

Hazard Identified	Likelihood	Consequence	Score	Comments (ie when and where hazard is present, task/activity)	Hierarchy of control	Current Controls	Action required Y/N
Can anyone be crushed by:							
<input checked="" type="checkbox"/> Plant falling or unexpected movement of the plant eg <input checked="" type="checkbox"/> Tipping <input checked="" type="checkbox"/> Falling <input checked="" type="checkbox"/> Rolling over <input checked="" type="checkbox"/> Rolling forward <input type="checkbox"/> The plant's load <input checked="" type="checkbox"/> Under/between plant and a structure eg wall <input type="checkbox"/> Inability to apply brake <input checked="" type="checkbox"/> Falling off the plant <input checked="" type="checkbox"/> Part of the plant collapsing/changing shape <input type="checkbox"/> Other issues _____ <input type="checkbox"/> No <input type="checkbox"/> NA	UNLIKELY	MAJOR	MEDIUM	Unstable ground. Unexpected movement. Working near structures. Sudden reversing. Operator not wearing seatbelt. Working near pedestrians. Working on plant during maintenance and servicing.	<input checked="" type="checkbox"/> EI <input type="checkbox"/> Su <input type="checkbox"/> En <input checked="" type="checkbox"/> Is <input checked="" type="checkbox"/> Ad <input checked="" type="checkbox"/> PPE	Neutral start switch fitted. Travel alarm and beacon fitted. Pedals are non-slip. Warning decals fitted. Park brake operational. Control pod operational. ROPS/FOPS structure fitted. Seatbelt fitted. Handrails fitted. SWL decals fitted. Do not lift above personnel decal fitted. Induction.	N
Can anyone be cut, stabbed or punctured, amputated by coming into contact with:							
<input checked="" type="checkbox"/> Moving plant or parts <input type="checkbox"/> Sharp or flying objects <input checked="" type="checkbox"/> Work pieces ejected <input type="checkbox"/> Work pieces disintegrating <input type="checkbox"/> Other issues _____ <input type="checkbox"/> No <input type="checkbox"/> NA	UNLIKELY	MAJOR	MEDIUM	Pedestrians to keep clear 30 metres. Quick hitch failure. Moving blade or bucket.	<input checked="" type="checkbox"/> EI <input type="checkbox"/> Su <input type="checkbox"/> En <input checked="" type="checkbox"/> Is <input checked="" type="checkbox"/> Ad <input checked="" type="checkbox"/> PPE	Warning decals fitted. Induction.	N

LEGEND	
<input type="checkbox"/> EI = Elimination	<input type="checkbox"/> Is = Isolation
<input type="checkbox"/> Su = Substitution	<input type="checkbox"/> Ad = Administration
<input type="checkbox"/> En = Engineering	<input type="checkbox"/> PPE = Personal Protective Equipment

Hazard Identified	Likelihood	Consequence	Score	Comments (ie when and where hazard is present, task/activity)	Hierarchy of control	Current Controls	Action required Y/N
Can anyone be burnt due to friction?							
<input type="checkbox"/> Contact with moving parts or surface of the plant <input type="checkbox"/> Material handled by the plant <input type="checkbox"/> Other issues _____ <input checked="" type="checkbox"/> No <input type="checkbox"/> NA					<input type="checkbox"/> EI <input type="checkbox"/> Su <input type="checkbox"/> En <input type="checkbox"/> Is <input type="checkbox"/> Ad <input type="checkbox"/> PPE		N
Can anyone be struck by moving objects due to:							
<input checked="" type="checkbox"/> Plant/materials being ejected <input checked="" type="checkbox"/> Plant/material movement <input type="checkbox"/> Other issues _____ <input type="checkbox"/> No <input type="checkbox"/> NA	UNLIKELY	MAJOR	MEDIUM	Load may shift, pedestrians to keep clear 30 metres. Unexpected plant movement	<input type="checkbox"/> EI <input type="checkbox"/> Su <input checked="" type="checkbox"/> En <input checked="" type="checkbox"/> Is <input checked="" type="checkbox"/> Ad <input checked="" type="checkbox"/> PPE	Travel alarm and beacon fitted. Keep clear decals fitted. Swing area decals fitted. Induction for correct operation. ROPS/FOPS structure fitted.	N
Can anyone suffocate due to:							
<input type="checkbox"/> Lack of oxygen <input checked="" type="checkbox"/> Atmospheric contamination <input type="checkbox"/> Engulfment <input type="checkbox"/> Other issues _____ <input type="checkbox"/> No <input type="checkbox"/> NA	RARE	MAJOR	MEDIUM	When working in confined spaces operator may be overcome by exhaust fumes.	<input checked="" type="checkbox"/> EI <input type="checkbox"/> Su <input type="checkbox"/> En <input type="checkbox"/> Is <input checked="" type="checkbox"/> Ad <input checked="" type="checkbox"/> PPE	Training for confined spaces must be completed before undertaking this type of work. Induction.	N

LEGEND

<input type="checkbox"/> EI = Elimination	<input type="checkbox"/> Is = Isolation
<input type="checkbox"/> Su = Substitution	<input type="checkbox"/> Ad = Administration
<input type="checkbox"/> En = Engineering	<input type="checkbox"/> PPE = Personal Protective Equipment

Hazard Identified	Likelihood	Consequence	Score	Comments (ie when and where hazard is present, task/activity)	Hierarchy of control	Current Controls	Action required Y/N
Can anyone be burnt due to:							
High/low temperature <input type="checkbox"/> Naked flame <input checked="" type="checkbox"/> Steam <input type="checkbox"/> Laser beams <input checked="" type="checkbox"/> Other issues _____ <input type="checkbox"/> No <input type="checkbox"/> NA	UNLIKELY	FIRST AID	MEDIUM	When inspecting radiator. On exhaust.	<input type="checkbox"/> EI <input type="checkbox"/> Su <input checked="" type="checkbox"/> En <input type="checkbox"/> Is <input checked="" type="checkbox"/> Ad <input checked="" type="checkbox"/> PPE	Hot coolant decal fitted. Hot exhaust decal fitted. Exhaust located out of reach of operating position, and all pedestrians to keep clear.	N
Can anyone be affected by temperature extremes?							
<input checked="" type="checkbox"/> Exposure to high temperature <input checked="" type="checkbox"/> Exposure to low temperature <input type="checkbox"/> Other issues _____ <input type="checkbox"/> No <input type="checkbox"/> NA	RARE	FIRST AID	LOW	When working in extremes of temperature.	<input type="checkbox"/> EI <input type="checkbox"/> Su <input checked="" type="checkbox"/> En <input type="checkbox"/> Is <input checked="" type="checkbox"/> Ad <input checked="" type="checkbox"/> PPE	Sunscreen to be worn. Appropriate clothing to be worn. Induction and training.	N
Can anyone slip, trip or fall due to:							
<input checked="" type="checkbox"/> The location of the plant <input checked="" type="checkbox"/> Uneven work surfaces <input type="checkbox"/> Lack of safe guards (eg rails) <input checked="" type="checkbox"/> Slippery work surfaces <input type="checkbox"/> Other issues _____ <input type="checkbox"/> No <input type="checkbox"/> NA	POSSIBLE	FIRST AID	MEDIUM	When working on uneven ground. When entering and exiting plant.	<input type="checkbox"/> EI <input type="checkbox"/> Su <input checked="" type="checkbox"/> En <input type="checkbox"/> Is <input checked="" type="checkbox"/> Ad <input checked="" type="checkbox"/> PPE	Seatbelts must be worn at all times. Maintain 3 points of contact when entering or exiting machine. Handrails fitted. Safety decals fitted. Steps to be kept clean.	N

LEGEND	
<input type="checkbox"/> EI = Elimination	<input type="checkbox"/> Is = Isolation
<input type="checkbox"/> Su = Substitution	<input type="checkbox"/> Ad = Administration
<input type="checkbox"/> En = Engineering	<input type="checkbox"/> PPE = Personal Protective Equipment

Hazard Identified	Likelihood	Consequence	Score	Comments (ie when and where hazard is present, task/activity)	Hierarchy of control	Current Controls	Action required Y/N
Can anyone come into contact with fluids or gases under high pressure due to:							
<input type="checkbox"/> Failure of the plant <input type="checkbox"/> Nature of the plant <input type="checkbox"/> Other issues _____ <input type="checkbox"/> No <input type="checkbox"/> NA	UNLIKELY	MAJOR	MEDIUM	Hydraulic hoses may burst. Radiator hoses may burst.	<input type="checkbox"/> EI <input type="checkbox"/> Su <input checked="" type="checkbox"/> En <input type="checkbox"/> Is <input checked="" type="checkbox"/> Ad <input checked="" type="checkbox"/> PPE	High pressure fluid decals fitted. Hose clamps fitted. Hose covers fitted. Hoses in good condition and correct maintenance to be continued.	N
Can anyone injured due to ergonomic issues due to:							
<input checked="" type="checkbox"/> Repetitive body movement or posture <input checked="" type="checkbox"/> Insufficient space <input type="checkbox"/> Excessive effort (push/pull) <input type="checkbox"/> Working at a height <input type="checkbox"/> Seating design <input type="checkbox"/> Poor lighting <input type="checkbox"/> Other issues _____ <input checked="" type="checkbox"/> No <input type="checkbox"/> NA	POSSIBLE	FIRST AID	MEDIUM	Long periods of operation	<input type="checkbox"/> EI <input type="checkbox"/> Su <input checked="" type="checkbox"/> En <input type="checkbox"/> Is <input checked="" type="checkbox"/> Ad <input checked="" type="checkbox"/> PPE	Ergonomic and adjustable seat fitted. Low stress controls fitted. Good lighting fitted. Control knobs easy to reach. Operator to take correct break periods.	N
Is there a current operators manual?							
Yes							N

LEGEND	
<input type="checkbox"/> EI = Elimination	<input type="checkbox"/> Is = Isolation
<input type="checkbox"/> Su = Substitution	<input type="checkbox"/> Ad = Administration
<input type="checkbox"/> En = Engineering	<input type="checkbox"/> PPE = Personal Protective Equipment

Hazard Identified	Likelihood	Consequence	Score	Comments (ie when and where hazard is present, task/activity)	Hierarchy of control	Current Controls	Action required Y/N
Can anyone be injured or suffer ill health from exposure to other hazards?							
<input type="checkbox"/> Chemicals <input type="checkbox"/> Radiation <input checked="" type="checkbox"/> Fumes <input checked="" type="checkbox"/> Dusts <input type="checkbox"/> Vibration <input checked="" type="checkbox"/> Noise <input type="checkbox"/> Toxic gases or vapours <input type="checkbox"/> Other issues _____ <input type="checkbox"/> No <input type="checkbox"/> NA	UNLIKELY	MAJOR	MEDIUM	Working in confined spaces. Long periods of operation	<input type="checkbox"/> EI <input type="checkbox"/> Su <input checked="" type="checkbox"/> En <input type="checkbox"/> Is <input checked="" type="checkbox"/> Ad <input checked="" type="checkbox"/> PPE	No excessive fumes at high idle. Falls below 85Db limit. Hearing protection decal fitted. Operator to be trained in correct safety procedure for dusty work environments.	N
Does the plant generate significant environmental hazards							
<input type="checkbox"/> Energy consumption <input type="checkbox"/> Water consumption <input type="checkbox"/> Hazardous waste <input type="checkbox"/> Hazardous emissions <input type="checkbox"/> Nuisance noise <input type="checkbox"/> Produce ignition to the surrounding area <input type="checkbox"/> Other issues _____ <input checked="" type="checkbox"/> No <input type="checkbox"/> NA					<input type="checkbox"/> EI <input type="checkbox"/> Su <input type="checkbox"/> En <input type="checkbox"/> Is <input type="checkbox"/> Ad <input type="checkbox"/> PPE	Fitted with emissions compliant engine. Noise level below 85Db limit.	N

STEP 3 : ACTION REQUIRED BY MANAGER/SUPERVISOR/AUTHORISED PERSON

- If no actions required and residual risk is medium to very high, the activity and the hazard(s) have been transferred to the Hazard Register and communicated to the relevant personnel.

FITTED WITH AN SGA PULL PIN HITCH

RISK ASSESSMENT TABLES

Likelihood Table

CATEGORY	DESCRIPTION
Almost Certain	Incident will occur at some time (0 – 1 month)
Likely	Incident could occur at some time (1 month – 1 year)
Possible	Incident is possible to occur (1 year – 2 years)
Unlikely	Incident is possible, but unlikely to occur (2 years – 5 years)
Rare	Cannot imagine that this could occur (over 5 years)

Consequences Table

CATEGORY	DESCRIPTION
Minor	Effects unlikely to last until the next day.
First Aid	Likely to affect employee the next day.
Major	Medical Treatment injury needs formal medical treatment
Critical	Injury requiring extensive medical treatment and/or hospitalization
Catastrophic	Injury resulting in death or permanent incapacity

Risk Score Calculator

Likelihood	Consequences				
	Minor	First Aid	Major	Critical	Catastrophic
Almost certain	Medium	High	High	Very High	Very High
Likely	Medium	Medium	High	High	Very High
Possible	Low	Medium	High	High	High
Unlikely	Low	Low	Medium	Medium	High
Rare	Low	Low	Medium	Medium	High

Risk Priority Table

Descriptor	Priority	Action
Very High	1	Immediate action required. The activity should cease immediately and short term safety controls implemented. Notify Manager and assess activity.
High	2	Implement short term safety controls immediately. Notify Manager and assess activity
Medium	3	Short term safety controls implemented to minimise risk of injury. Notify Manager and assess activity. Corrective Actions within one month.
Low	4	Notify Manager and assess activity. Corrective Actions within three months (if possible).

Safety around operating plant

Machines have blind spots where operators may not see people or objects nearby. The following diagrams illustrate typical examples of blind spots for some common mobile plant.

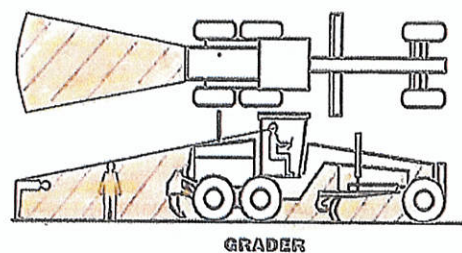
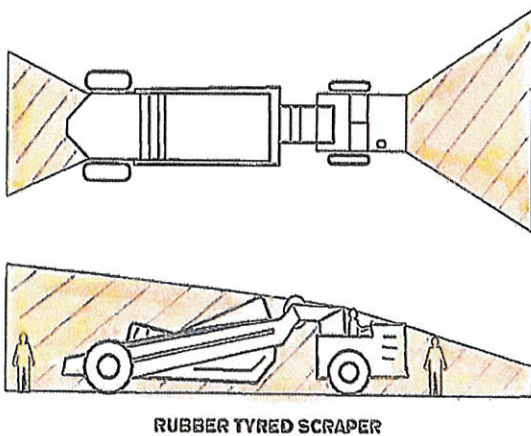
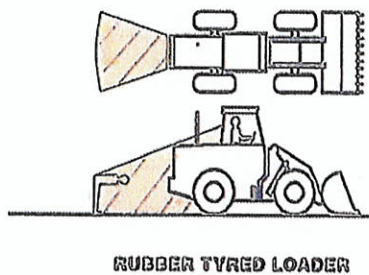
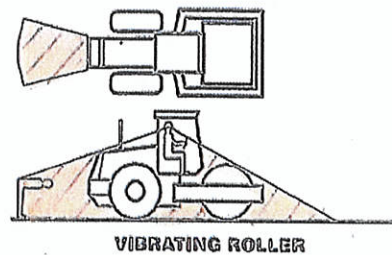
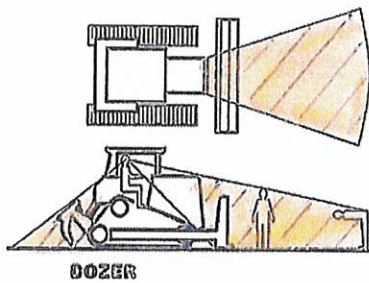
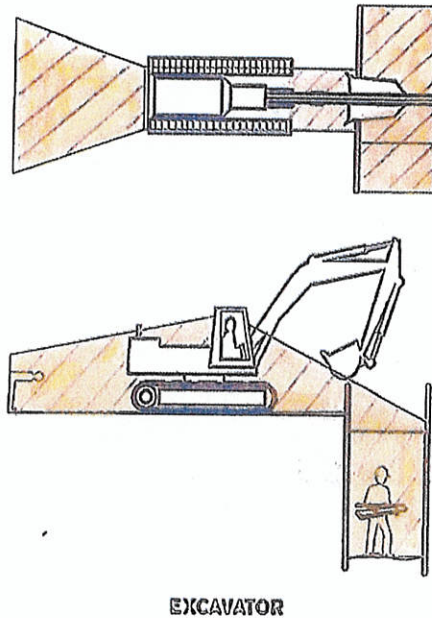
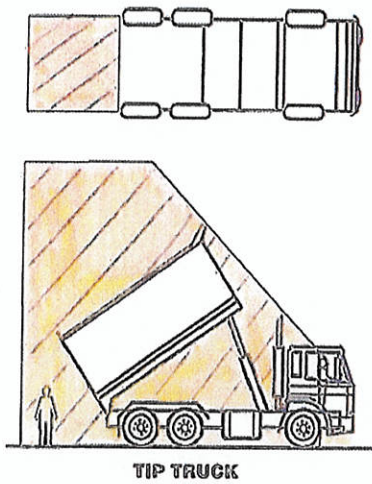

BLIND SPOTS