



# Instruction Manual

Single Acting, 2 Speed Hand Pump  
Model – P-235 and P-235L



**P-235 - Maximum Operating Pressure – 700 bar**  
**P-235L - Maximum Operating Pressure – 240 bar**



This is a safety alert symbol. It is used to alert you to potential personal injury hazards. Obey all safety messages that follow this symbol to avoid injury or death

## 1.0 Product Information

DURAPAC – Hand Pumps are engineered to meet Industrial Standards for Performance and Safety. The P-235 and P-235L models are a single-acting, two speed, two way valve design, steel bodied manual hand pump. They are best suited where manual, portable, hydraulic power is required.

Both models have a low handle effort for ease of operation and large, easy to grip external pressure release knobs. The P-235 model incorporates a convenient carry handle.

Special skill, knowledge and training may be required for a specific task and the product may not be suitable for all jobs. The user must ultimately make the decision regarding suitability of the product for any given task and assume the responsibility of safety for all in the work area. Contact a Durapac representative if you are unsure of your hand pumps suitability for a particular application.

## 2.0 Receiving Instructions

It is recommended prior to use that an inspection be done by qualified personnel and that any missing or damaged parts, decals, warning/safety labels or signs are replaced with Durapac authorised replacement parts only. Any hand pump that appears to be damaged in any way, is worn, leaking or operates abnormally should be removed from service immediately until such time as repairs can be made. Any hand pump that has been or suspected to have been subject to a shock load should be removed from service immediately until inspected by a Durapac authorised service centre. Owners and operators of this equipment should be aware that the use and subsequent repair of this equipment may require specialised training and knowledge.

## 3.0 Safety

Save these instructions. For your safety, read and understand the information contained within. The owner and operator should have an understanding of this product and safe operating procedures before attempting to use this product. Instructions and safety information should be conveyed in the operator's native language before use of this product is authorised. Make certain that the operator thoroughly understands the inherent dangers associated with the use and misuse of the product. If any doubt exists as to the safe and proper use of this product as outlined in this factory authorised manual, remove from service immediately.



### **DANGER:**

- To avoid personal injury keep hands and feet away from work area during operation
- **Do NOT** handle pressurised hoses. Escaping oil under pressure can penetrate the skin causing serious injury. If oil is injected under the skin, see a doctor immediately
- Stay clear of loads supported by hydraulics. A pump, when used as a load lifting device, should never be used as a load holding device. After the load has been raised or lowered, it must always be blocked mechanically

**WARNING:**

- The system operating pressure must not exceed the pressure rating of the lowest rated component in the system. Install pressure gauges in the system to monitor operating pressure. It is your window to what is happening in the system
- Always wear protective gear when operating hydraulic equipment. The operator must take precaution against injury due to failure of the tool or work piece(s)
- **Do NOT** hold or stand directly in line with any hydraulic connections while pressurising
- **Do NOT** attempt to disconnect hydraulic connections under pressure. Release all line pressure before disconnecting hoses
- All personnel must be clear before lowering load or depressurising the system
- **Do NOT** attempt to lift a load weighing more than the capacity of the cylinder

**IMPORTANT:**

- If at any stage, the safety related decals become hard to read, these must be replaced
- Minimum age of the operator must be 18 years. The operator must have read and understood all instructions, safety issues, cautions and warnings before starting to operate the equipment. The operator is responsible for this activity towards other persons
- **Do NOT** lift hydraulic equipment by the hoses or couplers. Use the carrying handle or other means of safe transport
- Hydraulic equipment must only be serviced by a qualified hydraulic technician. For repair service, contact the Durapac authorised service centre in your area. To protect your warranty, use only high quality hydraulic oil

**CAUTION:**

- **KEEP HYDRAULIC EQUIPMENT AWAY FROM FLAMES AND HEAT.** Hydraulic fluid can ignite and burn. Excessive heat will soften packings and seals, resulting in fluid leaks. Heat also weakens hose materials and packings. For optimum performance do not expose equipment to temperatures of 65°C (150°F) or higher. Protect all equipment from weld spatter
- No alteration should be made to this device

### 3.1 Hydraulic Pumps

- **Do** use a gauge or other load measuring instrument to verify load
- **Do NOT** exceed the rated capacity of the pump or any equipment in the system. Burst hazard exists if connection pressure exceeds rated pressure
- **Do NOT** operate the system with bent or damaged couplers or damaged threads
- **Do NOT** subject the pump and its components to shock loads
- Use only Durapac approved accessories and components

- **Do NOT** connect to an application which can return more oil to the reservoir than the pump reservoir can hold
- **Do NOT** connect pump to a hydraulic system that is powered by another pump

**3.2 Hydraulic Hoses & Fluid Transmission Lines**

- Avoid short runs of straight line tubing. Straight line runs do not provide for expansion and contraction due to pressure and/or temperature changes
- Reduce stress in tube lines. Long tubing runs should be supported by brackets or clips. Before operating the pump, connections should be tightened securely and leak-free. Over tightening can cause premature thread failure or high pressure fittings to burst
- Should a hydraulic hose ever rupture, burst or need to be disconnected, immediately shut off the pump and release all pressure. Never attempt to grasp a leaking pressurised hose with your hands. The force of escaping hydraulic fluid can inflict injury
- **Do NOT** subject the hose to potential hazard such as fire, sharp objects, extreme heat or cold or heavy impact
- **Do NOT** allow the hose to kink, twist, curl, crush, cut or bend so tightly that the fluid flow within the hose is blocked or reduced. Periodically inspect the hose for wear
- Hose material and coupler seals must be compatible with the hydraulic fluid used. Hoses also must not come in contact with corrosive materials such as battery acid, creosote-impregnated objects and wet paint. Never paint a coupler or hose

**FAILURE TO HEED THESE WARNINGS MAY RESULT IN PERSONAL INJURY AS WELL AS PROPERTY DAMAGE.**

**4.0 Installation**

**⚠ IMPORTANT:** Always secure threaded port connections with high grade, non-hardening pipe thread sealant. Teflon tape can be used if only one layer of tape is used and it is applied carefully, two threads back, to prevent the tape from being introduced into hydraulic system, which could cause jamming of precision-fit parts

**4.1** Familiarise yourself with the specifications and illustrations in this owner’s manual. Know your hand pump, its limitations and how it operates before attempting to use. Refer to the specification chart below or if in doubt, contact a Durapac representative.

Model Number	Used with Cylinder	Pressure Rating (bar)		Usable Oil Capacity (cc)	Oil Volumes per Stroke (cc)		Oil Port Thread	Max. Handle Effort (kg)	Weight (kg)
		1st Stage	2nd Stage		1st Stage	2nd Stage			
P-235	S/A	13.8	700	350	7.0	1.0	3/8" NPTF	34	5.5
P-235L	S/A	13.8	240	350	13.0	2.8	3/8" NPTF	25	5.5

**4.2** Remove the manifold plug and then connect oil output port to suitable fittings and application/cylinder.

**4.3** Check all system fittings and connections to be sure they are tight and leak free.

- 4.4 Check oil level in reservoir before operating pump.
- 4.5 Remove air from the system – Air can accumulate in the hydraulic system during the initial setup or after prolonged use, causing the pump to respond slowly or in an unstable manner. Should removal of air from pump be required, please follow the steps in 6.2 – Bleeding Air from the System in the Maintenance Section.

## 5.0 Operation



### IMPORTANT:

- **Do NOT** add extensions to the pump handle. Extensions cause unstable pump operation
- In certain situations the pump handle can "kick back". Always keep your body to the side of the pump, away from the line of force of the handle
- **Do NOT** operate a pump that is disconnected from application. If operated in this condition, the hose and connections will become pressurised. This increases burst hazard. Damage may occur to pump and its components

Both P235 and P-235L models may be operated in a horizontal or in a vertical position with the head pointing down as shown.

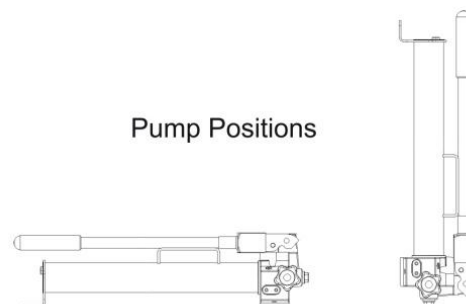

Figure 1 – Hand Pump Operation

### 5.1 Using a Two-Speed Pump

This pump provides 2-stage flow. Under no-load, the pump operates in the high flow first stage for rapid advance. When the load is contacted, the pump automatically shifts to the second stage for building pressure. After the pump shifts, pumping takes less effort.

**Note:** To reduce handle effort at high pressure, take short strokes. Maximum leverage is obtained in the last 5° of stroke. For best performance, operate pump handle at moderate speed during the high flow first stage. Rapid handle speed in the first stage will prevent the pump from delivering full volume of oil.

### 5.2 Advance and Retraction of Single-Acting Applications

- 5.2.1 Turn the pump's release valve clockwise to a closed position.

 **IMPORTANT:** Only hand tighten the valve. Applying too much force to the valve may damage the valve stem.

5.2.2 Work the pump handle up and down to send oil through the hose to the cylinder. This will cause the piston to extend to the work piece.

5.2.3 Monitor the pressure gauge while completing the application.

**Note:** The pump is equipped with an overload valve that will bypass oil back into the pump reservoir in an overload situation (when the system meets maximum pressure). In this case, continued pumping will have no effect on the system. If an overload situation commonly occurs, a higher capacity set is needed.

5.2.4 To release pressure, slowly turn the release valve counter clockwise. The release speed is controlled by how fast the valve is opened.

### 5.3 Relief Valve Adjustment

All pumps contain a factory set relief valve to prevent over-pressurisation of the system.

## 6.0 Maintenance



### IMPORTANT:

- Check oil level regularly
- Use only good quality hydraulic fluid. **Do NOT** use brake fluid, transmission fluid, turbine oil, motor oil, alcohol, glycerine etc. Use of anything other than good quality hydraulic oil will void warranty and damage the pump, hose, and application. We recommend Durapac Hydraulic Oil or equivalent
- Equipment must only be serviced by a qualified hydraulic technician. For repair service, contact your local Durapac authorised service centre
- Tighten connections as needed. Use non-hardening pipe thread compound when servicing connections.

Dirt, sand, etc. will quickly ruin any hydraulic system. Ensure that couplings are clean and free of foreign matter. After each use, clean couplings and attach dust caps.

Maintenance is required when wear or leakage is noticed. Periodically inspect all components to detect any problem that may require service and maintenance.

### 6.1 Adding Hydraulic Fluid

**WARNING:** Always add oil with cylinders fully retracted (or extended, if pull cylinders) or the system will contain more oil than the reservoir can hold

6.1.1 Depressurise and disconnect hydraulic hose from application/cylinder.

6.1.2 Put the pump in a vertical position (pump head face down); remove oil filler plug located on rear of the pump reservoir.

6.1.3 Use a small funnel to fill the oil to approximately 45 mm from the top of the oil filler hole.

6.1.4 Bleed air from system if necessary.

- 6.1.5 Wipe up any spilled fluid and reinstall the air vent plug/reservoir cap.

## 6.2 Bleeding Air from the System

- 6.2.1 Repeat Steps 6.1.1 to 6.1.3 (above), if required.
- 6.2.2 Invert cylinder and place at a lower level than the pump reservoir.
- 6.2.3 Extend and retract the cylinder several times without putting a load on the system. Air will be released into the pump reservoir.
- 6.2.4 Recheck oil level after removing air.

## 6.3 Changing Hydraulic Fluid

 For best results, change fluid once a year or every 300 hours of use

- 6.3.1 Repeat Steps 6.1.1 to 6.1.2 (above).
- 6.3.2 Pour used fluid into a sealable container.
- 6.3.3 Repeat Steps 6.1.3 to 6.1.5 (above).
- 6.3.4 Dispose of fluid in accordance with local regulations.

## 6.4 Lubrication

To extend pump life and improve performance, lubricate the beam pin (A), cross pin (B), and piston head (C) regularly, using roller bearing grease.

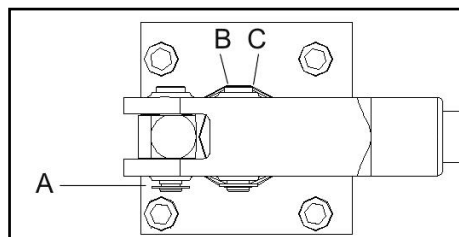

*Figure 2 - Lubrication*

## 6.5 Storage

- 6.5.1 When not in use, depressurise and disconnect the hydraulic pump from the application.
- 6.5.2 Wipe clean thoroughly and store in a clean, dry environment. Avoid temperature extremes.
- 6.5.3 Shield pump with a protective cover.

**7.0 Troubleshooting**

<b>Problem</b>	<b>Cause</b>	<b>Solution</b>
<b>Pump loses pressure</b>	Leaking system components	<ul style="list-style-type: none"> <li>• Repair or replace as necessary</li> </ul>
<b>Pump not delivering fluid</b>	Low fluid level in reservoir	<ul style="list-style-type: none"> <li>• Check fluid level</li> </ul>
	Worn seats	<ul style="list-style-type: none"> <li>• Repair seats</li> <li>• Replace pump body</li> </ul>
<b>Pump does not reach rated capacity</b>	Low fluid level in reservoir	<ul style="list-style-type: none"> <li>• Check fluid level</li> </ul>
	Leaking system components	<ul style="list-style-type: none"> <li>• Repair or replace as necessary</li> </ul>
	Fluid leaking past inlet or outlet checks	<ul style="list-style-type: none"> <li>• Repair inlet or outlet checks</li> <li>• Replace high pressure piston seal</li> </ul>
<b>Pump handle has a “spongy” feel</b>	Air trapped in system	<ul style="list-style-type: none"> <li>• Refer to 6.2 – Bleeding Air from the System</li> </ul>
	Too much fluid in reservoir	<ul style="list-style-type: none"> <li>• Check fluid level</li> </ul>
<b>Cylinder piston will not extend</b>	Loose couplers	<ul style="list-style-type: none"> <li>• Tighten couplers</li> </ul>
	Low fluid level in pump reservoir	<ul style="list-style-type: none"> <li>• Fill and bleed the system</li> </ul>
	Leaking cylinder seals	<ul style="list-style-type: none"> <li>• Replace worn seals. Look for excessive contamination or wear</li> </ul>
<b>Cylinder piston extends only partially</b>	Low fluid level in pump reservoir	<ul style="list-style-type: none"> <li>• Fill and bleed the system</li> </ul>
	Load in above capacity of system	<ul style="list-style-type: none"> <li>• Use correct equipment</li> </ul>
<b>Cylinder piston extends slower than normal</b>	Loose couplers	<ul style="list-style-type: none"> <li>• Tighten couplers</li> </ul>
	Restricted hydraulic line or fitting	<ul style="list-style-type: none"> <li>• Clean and replace if damaged</li> </ul>
	Pump not operating correctly	<ul style="list-style-type: none"> <li>• Check pump’s operating instructions</li> <li>• Repair or replace as necessary</li> </ul>
	Low fluid level in pump reservoir	<ul style="list-style-type: none"> <li>• Fill and bleed the system</li> </ul>
<b>Cylinder does not hold pressure</b>	Leaky connection	<ul style="list-style-type: none"> <li>• Clean, reseal with thread sealant, and tighten connection</li> </ul>
	Leaking cylinder seals	<ul style="list-style-type: none"> <li>• Replace worn seals. Look for excessive contamination or wear. Replace contaminated fluid</li> </ul>
	Pump or valve not operating correctly	<ul style="list-style-type: none"> <li>• Repair or replace as necessary</li> </ul>
<b>Cylinder will not retract or retracts slower than normal</b>	Closed pump release valve	<ul style="list-style-type: none"> <li>• Open pump release valve</li> </ul>
	Loose couplers	<ul style="list-style-type: none"> <li>• Tighten couplers</li> </ul>
	Blocked hydraulic lines	<ul style="list-style-type: none"> <li>• Clean and flush lines</li> </ul>
	Weak or broken retraction springs	<ul style="list-style-type: none"> <li>• Send to a Durapac authorised service centre for repair</li> </ul>
	Internally damaged cylinder	<ul style="list-style-type: none"> <li>• Send to a Durapac authorised service centre for repair</li> </ul>
	Pump reservoir too full	<ul style="list-style-type: none"> <li>• Drain fluid to correct level</li> </ul>



**8.0 Parts Breakdown and List**

**8.1 P-235 Model**

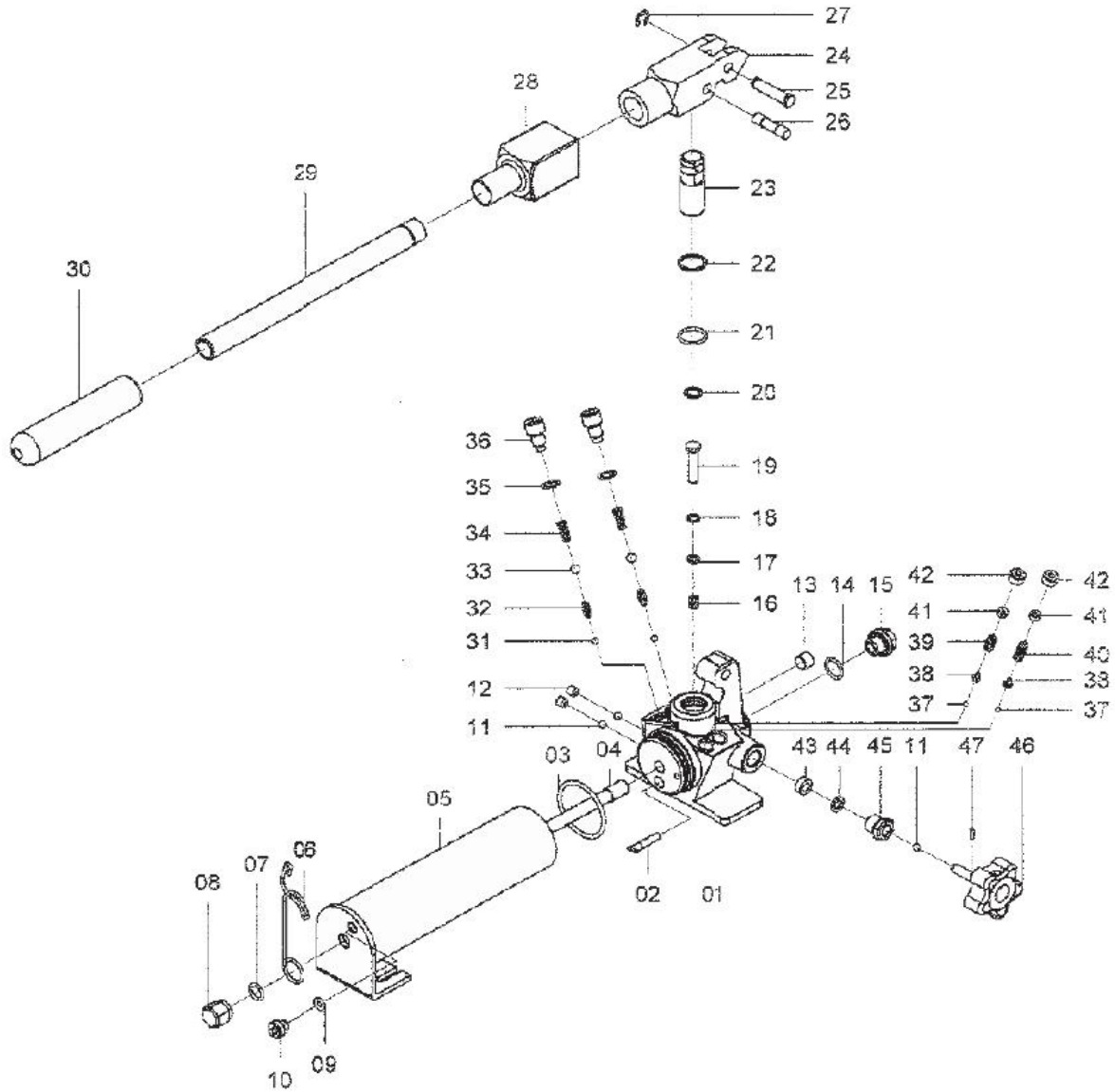

Item	Description	Part No.	Qty	Item	Description	Part No.	Qty	Item	Description	Part No.	Qty
1	Pump housing	ZAL1185	1	17	O-ring*	ZAL1273	1	33	Steel ball	ZAL1368	2
2	Oil filter	ZAL1387	1	18	Back-up ring*	ZAL1227	1	34	Spring	ZAL1339	2
3	O-ring*	ZAL1221	1	19	Pump piston	ZAL1106	1	35	Washer	ZAL1340	2
4	Tie rod	ZAL1104	1	20	Snap ring	ZAL1331	1	36	Valve cover screw	ZAL1286	2
5	Reservoir	ZAL1005	1	21	O-ring*	ZAL1279	1	37	Steel ball	ZAL1370	2
6	Fixing hook	ZAL1347	1	22	Back-up ring*	ZAL1230	1	38	Spring end cap	ZAL1096	2
7	O-ring*	ZAL1208	1	23	Pump piston	ZAL1107	1	39	Short separator spring	ZAL1350	1
8	Nipple	ZAL1105	1	24	Yoke	ZAL1176	1	40	Long separator spring	ZAL1346	1
9	O-ring*	ZAL1210	1	25	Yoke pin	ZAL1095	1	41	Screw	ZAL1175	2
10	Air release screw	ZAL1285	1	26	Piston pin	ZAL1108	1	42	Set screw	ZAL1294	2
11	Steel ball	ZAL1366	3	27	Retaining ring	ZAL1327	1	43	Oil seal*	ZAL1224	1
12	Screw	ZAL1284	2	28	Yoke cover	ZAL1226	1	44	Washer	ZAL1351	1
13	Set screw	ZAL1297	1	29	Handle	ZAL1082	1	45	Release nut	ZAL1291	1
14	O-ring	ZAL1229	1	30	Handle grip	ZAL1263	1	46	Release valve	ZAL1004	1
15	Nipple	ZAL1264	1	31	Steel ball	ZAL1367	2	47	Pin	ZAL1371	1
16	Spring	ZAL1348	1	32	Spring	ZAL1344	2		Repair kit	ZAL1407	1

**8.2 P-235L Model**

**\*\*\*Supersedes all previous versions\*\*\***

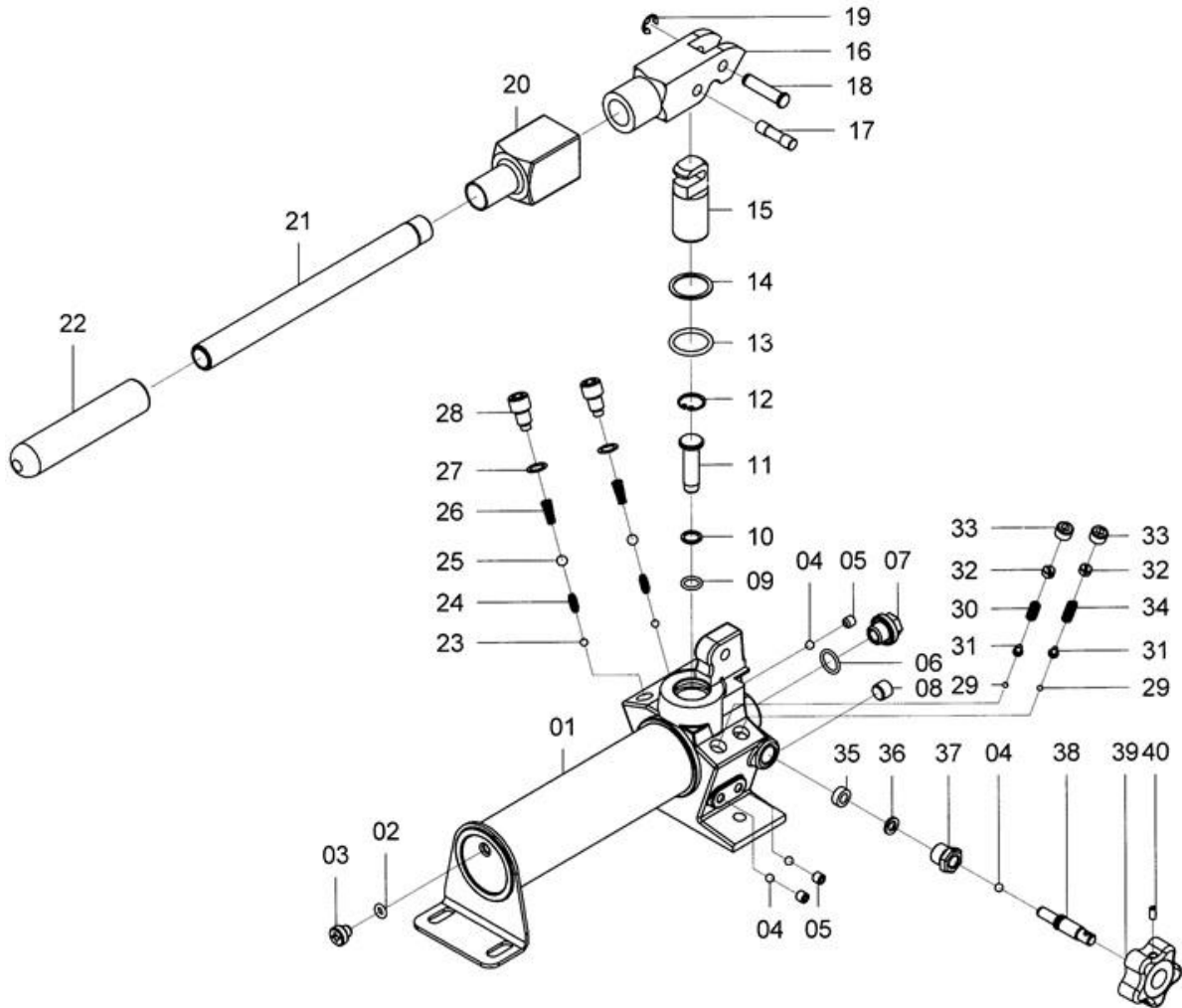

Item	Description	Part No.	Qty	Item	Description	Part No.	Qty	Item	Description	Part No.	Qty
1	Pump housing	ZAL1011	1	15	Retaining ring	ZAL1103	1	28	Valve cover screw	ZAL1286	2
2	O-ring*	ZAL1210	1	16	Yoke	ZAL1176	1	29	Steel ball	ZAL1370	2
3	Air release screw	ZAL1285	1	17	Piston pin	ZAL1108	1	30	Short separator spring	ZAL1350	1
4	Steel ball	ZAL1366	4	18	Yoke pin	ZAL1095	1	31	Spring end cap	ZAL1096	2
5	Screw	ZAL1284	3	19	Retaining ring	ZAL1327	1	32	Screw	ZAL1175	2
6	O-ring	ZAL1229	1	20	Yoke cover	ZAL1226	1	33	Set screw	ZAL1294	2
7	Nipple	ZAL1264	1	21	Handle	ZAL1067	1	34	Long separator spring	ZAL1346	1
8	Screw	ZAL1297	1	22	Handle grip	ZAL1263	1	35	Oil seal	ZAL1224	1
9	O-ring*	ZAL1272	1	23	Steel ball	ZAL1367	2	36	Washer	ZAL1351	1
10	Back-up ring*	ZAL1209	1	24	Spring	ZAL1344	2	37	Release nut	ZAL1291	1
11	Pump piston	ZAL1406	1	25	Steel ball	ZAL1368	2	38	Release valve screw	ZAL1292	1
12	Snap ring	ZAL1329	1	26	Spring	ZAL1339	2	39	Release valve	ZAL1388	1
13	O-ring*	ZAL1277	1	27	Washer	ZAL1340	2	40	Screw	ZAL1290	1
14	Back-up ring*	ZAL1225	1						Repair kit	ZAL1396	1

Items marked with a \* are contained within a standard Repair Kit.

Serial number, model and part number need to be quoted when ordering parts.