



An Oshkosh Corporation Company

Operation and Safety Manual

Original Instructions - Keep this manual with the machine at all times.

Boom Lift Models

450A Series II

450AJ Series II

S/N 0300160835-

S/N E300001114

to Present

ANSI **CE**



3121289
January 5, 2015

NOTE: *This manual also applies to machines with the following
Serial Numbers: 0300159794, 0300159795,
0300160088, 0300160456, and E300001067.*

FOREWORD

This manual is a very important tool! Keep it with the machine at all times.

The purpose of this manual is to provide owners, users, operators, lessors, and lessees with the precautions and operating procedures essential for the safe and proper machine operation for its intended purpose.

Due to continuous product improvements, JLG Industries, Inc. reserves the right to make specification changes without prior notification. Contact JLG Industries, Inc. for updated information.

SAFETY ALERT SYMBOLS AND SAFETY SIGNAL WORDS



This is the Safety Alert Symbol. It is used to alert you to the potential personal injury hazards. Obey all safety messages that follow this symbol to avoid possible injury or death

⚠ DANGER

INDICATES AN IMMINENTLY HAZARDOUS SITUATION. IF NOT AVOIDED, WILL RESULT IN SERIOUS INJURY OR DEATH. THIS DECAL WILL HAVE A RED BACKGROUND.

⚠ WARNING

INDICATES A POTENTIALLY HAZARDOUS SITUATION. IF NOT AVOIDED, COULD RESULT IN SERIOUS INJURY OR DEATH. THIS DECAL WILL HAVE AN ORANGE BACKGROUND.

⚠ CAUTION

INDICATES A POTENTIALLY HAZARDOUS SITUATION. IF NOT AVOIDED, MAY RESULT IN MINOR OR MODERATE INJURY. IT MAY ALSO ALERT AGAINST UNSAFE PRACTICES. THIS DECAL WILL HAVE A YELLOW BACKGROUND.

NOTICE

INDICATES INFORMATION OR A COMPANY POLICY THAT RELATES DIRECTLY OR INDIRECTLY TO THE SAFETY OF PERSONNEL OR PROTECTION OF PROPERTY.

⚠ WARNING

THIS PRODUCT MUST COMPLY WITH ALL SAFETY RELATED BULLETINS. CONTACT JLG INDUSTRIES, INC. OR THE LOCAL AUTHORIZED JLG REPRESENTATIVE FOR INFORMATION REGARDING SAFETY-RELATED BULLETINS WHICH MAY HAVE BEEN ISSUED FOR THIS PRODUCT.

NOTICE

JLG INDUSTRIES, INC. SENDS SAFETY RELATED BULLETINS TO THE OWNER OF RECORD OF THIS MACHINE. CONTACT JLG INDUSTRIES, INC. TO ENSURE THAT THE CURRENT OWNER RECORDS ARE UPDATED AND ACCURATE.

NOTICE

JLG INDUSTRIES, INC. MUST BE NOTIFIED IMMEDIATELY IN ALL INSTANCES WHERE JLG PRODUCTS HAVE BEEN INVOLVED IN AN ACCIDENT INVOLVING BODILY INJURY OR DEATH OF PERSONNEL OR WHEN SUBSTANTIAL DAMAGE HAS OCCURRED TO PERSONAL PROPERTY OR THE JLG PRODUCT.

For:

- Accident Reporting
- Product Safety Publications
- Current Owner Updates
- Questions Regarding Product Safety
- Standards and Regulations Compliance Information
- Questions Regarding Special Product Applications
- Questions Regarding Product Modifications

Contact:

Product Safety and Reliability Department
JLG Industries, Inc.
13224 Fountainhead Plaza
Hagerstown, MD 21742
USA

or Your Local JLG Office
(See addresses on inside of manual cover)

In USA:

Toll Free: 877-JLG-SAFE (877-554-7233)

Outside USA:

Phone: 240-420-2661
Fax: 301-745-3713
E-mail: ProductSafety@JLG.com

REVISION LOG

| | |
|----------------|-------------------|
| Original Issue | - June 19, 2012 |
| Revised | - June 29, 2012 |
| Revised | - April 1, 2013 |
| Revised | - October 1, 2014 |
| Revised | - January 5, 2015 |

| SECTION - PARAGRAPH, SUBJECT | PAGE |
|---|-------------|
| SECTION - 1 - SAFETY PRECAUTIONS | |
| 1.1 GENERAL | 1-1 |
| 1.2 PRE-OPERATION | 1-1 |
| Operator Training and Knowledge | 1-1 |
| Workplace Inspection | 1-2 |
| Machine Inspection | 1-3 |
| 1.3 OPERATION | 1-3 |
| General | 1-3 |
| Trip and Fall Hazards | 1-4 |
| Electrocution Hazards | 1-5 |
| Tipping Hazards | 1-7 |
| Crushing and Collision Hazards | 1-10 |
| 1.4 TOWING, LIFTING, AND HAULING | 1-11 |
| 1.5 MAINTENANCE | 1-11 |
| Maintenance Hazards | 1-11 |
| Battery Hazards | 1-13 |
| SECTION - 2 - USER RESPONSIBILITIES, MACHINE PREPARATION, AND INSPECTION | |
| 2.1 PERSONNEL TRAINING | 2-1 |
| Operator Training | 2-1 |
| Training Supervision | 2-1 |
| Operator Responsibility | 2-1 |
| 2.2 PREPARATION, INSPECTION, AND MAINTENANCE | 2-2 |
| Pre-Start Inspection | 2-4 |
| Function Check | 2-5 |

| SECTION - PARAGRAPH, SUBJECT | PAGE |
|---|-------------|
| SkyGuard Function Test | 2-6 |
| GENERAL | 2-10 |
| 2.3 OSCILLATING AXLE LOCKOUT TEST (IF EQUIPPED) | 2-12 |
| SECTION - 3 - MACHINE CONTROLS AND INDICATORS | |
| 3.1 GENERAL | 3-1 |
| 3.2 CONTROLS AND INDICATORS | 3-1 |
| Ground Control Station | 3-2 |
| Ground Control Indicator Panel | 3-8 |
| Platform Control Station | 3-11 |
| Platform Control Indicator Panel | 3-15 |
| SECTION - 4 - MACHINE OPERATION | |
| 4.1 DESCRIPTION | 4-1 |
| 4.2 OPERATING CHARACTERISTICS AND LIMITATIONS | 4-1 |
| Capacities | 4-1 |
| Stability | 4-2 |
| 4.3 ENGINE OPERATION | 4-2 |
| Starting Procedure | 4-2 |
| Shutdown Procedure | 4-3 |
| Fuel Reserve / Shut-Off System | 4-4 |
| 4.4 TRAVELING (DRIVING) | 4-6 |
| Traveling Forward and Reverse | 4-7 |
| 4.5 STEERING | 4-9 |
| 4.6 PLATFORM | 4-9 |
| Platform Level Adjustment | 4-9 |

TABLE OF CONTENTS

| SECTION - PARAGRAPH, SUBJECT | PAGE | SECTION - PARAGRAPH, SUBJECT | PAGE |
|--|-------------|--|-------------|
| | | SECTION - 5 - EMERGENCY PROCEDURES | |
| Platform Rotation | 4-9 | 5.1 GENERAL | 5-1 |
| 4.7 BOOM | 4-9 | 5.2 INCIDENT NOTIFICATION | 5-1 |
| Swinging the Boom | 4-10 | 5.3 EMERGENCY OPERATION | 5-2 |
| Raising and Lowering the Tower Boom | 4-10 | Operator Unable to Control Machine | 5-2 |
| Raising and Lowering the Main Boom | 4-10 | Platform or Boom Caught Overhead | 5-2 |
| Telescoping the Main Boom | 4-10 | 5.4 EMERGENCY TOWING PROCEDURES | 5-2 |
| 4.8 FUNCTION SPEED CONTROL | 4-10 | 5.5 MACHINE SAFETY SYSTEM OVERRIDE (MSSO) | |
| 4.9 MACHINE SAFETY SYSTEM OVERRIDE (MSSO) | | (CE ONLY) | 5-2 |
| (CE ONLY) | 4-11 | | |
| 4.10 SKYGUARD OPERATION | 4-11 | SECTION - 6 - GENERAL SPECIFICATIONS AND OPERATOR | |
| 4.11 AUXILIARY PUMP | 4-12 | MAINTENANCE | |
| 4.12 OSCILLATING AXLE LOCKOUT TEST (IF EQUIPPED) ... | 4-12 | 6.1 INTRODUCTION | 6-1 |
| 4.13 SHUT DOWN AND PARK | 4-13 | 6.2 OPERATING SPECIFICATIONS AND PERFORMANCE | |
| 4.14 LIFTING AND TIE DOWN | 4-13 | DATA | 6-1 |
| Lifting | 4-13 | Reach Specifications | 6-2 |
| Tie Down | 4-13 | Dimensional Data | 6-3 |
| 4.15 TOWING | 4-15 | Chassis | 6-3 |
| Prior to Towing | 4-15 | Major Component Weights | 6-4 |
| 4.16 DUAL FUEL SYSTEM (GAS ENGINE ONLY) | 4-16 | Capacities | 6-4 |
| Changing From Gasoline to LP Gas | 4-16 | Tires | 6-4 |
| Changing From LP Gas to Gasoline | 4-16 | Engine | 6-5 |
| | | Hydraulic Oil | 6-7 |
| | | Serial Number Location | 6-11 |

| SECTION - PARAGRAPH, SUBJECT | PAGE | SECTION - PARAGRAPH, SUBJECT | PAGE |
|---|-------------|-------------------------------------|-------------|
| 6.3 OPERATOR MAINTENANCE | 6-21 | | |
| 6.4 TIRES & WHEELS | 6-34 | | |
| Tire Inflation | 6-34 | | |
| Tire Damage | 6-34 | | |
| Tire Replacement | 6-34 | | |
| Wheel and Tire Replacement | 6-35 | | |
| Wheel Installation | 6-35 | | |
| 6.5 PROPANE FUEL FILTER REPLACEMENT | 6-37 | | |
| Removal | 6-37 | | |
| Installation | 6-38 | | |
| 6.6 PROPANE FUEL SYSTEM PRESSURE RELIEF | 6-38 | | |
| 6.7 SUPPLEMENTAL INFORMATION | 6-39 | | |

SECTION - 7 - INSPECTION AND REPAIR LOG

TABLE OF CONTENTS

SECTION - PARAGRAPH, SUBJECT

PAGE

SECTION - PARAGRAPH, SUBJECT

PAGE

This Page Left Blank Intentionally.

| FIGURE NUMBER - TITLE | PAGE | FIGURE NUMBER - TITLE | PAGE |
|---|-------------|--|-------------|
| 2-1. Basic Nomenclature - Sheet 1 of 2 | 2-7 | 6-2. Engine Operating Temperature Specifications - Caterpillar - Sheet 1 of 2 | 6-12 |
| 2-2. Basic Nomenclature - Sheet 2 of 2 | 2-8 | 6-3. Engine Operating Temperature Specifications - Caterpillar - Sheet 2 of 2 | 6-13 |
| 2-3. Daily Walk-Around Inspection - Sheet 1 of 3 | 2-9 | 6-4. Engine Operating Temperature Specifications - Deutz - Sheet 1 of 2 | 6-14 |
| 2-4. Daily Walk-Around Inspection - Sheet 2 of 3 | 2-10 | 6-5. Engine Operating Temperature Specifications - Deutz - Sheet 2 of 2 | 6-15 |
| 2-5. Daily Walk-Around Inspection - Sheet 3 of 3 | 2-11 | 6-6. Engine Operating Temperature Specifications - GM - Sheet 1 of 2..... | 6-16 |
| 3-1. Ground Control Station - A Models | 3-3 | 6-7. Engine Operating Temperature Specifications - GM - Sheet 2 of 2..... | 6-17 |
| 3-1. Ground Control Station - A Models with Machine Safety System Override (MSSO) (CE Only) | 3-4 | 6-8. Operator Maintenance and Lubrication Diagram - Deutz D2.9..... | 6-18 |
| 3-2. Ground Control Station - AJ Models | 3-5 | 6-9. Operator Maintenance and Lubrication Diagram - Deutz D2011 and CAT C2.2 | 6-19 |
| 3-3. Ground Control Station - AJ Models with Machine Safety System Override (MSSO) (CE Only) | 3-6 | 6-10. Operator Maintenance and Lubrication Diagram - GM Dual-Fuel | 6-20 |
| 3-4. Ground Control Indicator Panel | 3-9 | 6-11. Deutz D2011 Engine Dipsticks..... | 6-27 |
| 3-5. Platform Control Console | 3-12 | 6-12. Filter Lock Assembly | 6-37 |
| 3-6. Platform Control Indicator Panel..... | 3-16 | | |
| 4-1. Position of Least Forward Stability..... | 4-5 | | |
| 4-2. Position of Least Backward Stability | 4-6 | | |
| 4-3. Grade and Side Slopes | 4-8 | | |
| 4-4. Lifting and Tie Down Chart..... | 4-14 | | |
| 4-5. Drive Disconnect Hub..... | 4-15 | | |
| 4-6. Decal Installation - Sheet 1 of 6..... | 4-17 | | |
| 4-7. Decal Installation - Sheet 2 of 6..... | 4-18 | | |
| 4-8. Decal Installation - Sheet 3 of 6..... | 4-19 | | |
| 4-9. Decal Installation - Sheet 4 of 6..... | 4-20 | | |
| 4-10. Decal Installation - Sheet 5 of 6..... | 4-21 | | |
| 4-11. Decal Installation - Sheet 6 of 6..... | 4-22 | | |
| 6-1. Serial Number Locations | 6-11 | | |

LIST OF FIGURES

FIGURE NUMBER - TITLE

PAGE

FIGURE NUMBER - TITLE

PAGE

This Page Left Blank Intentionally.

| TABLE NUMBER - TITLE | PAGE | TABLE NUMBER - TITLE | PAGE |
|-----------------------------|-------------------------------------|-----------------------------|-------------|
| 1-1 | Minimum Approach Distances (M.A.D.) | 1-6 | |
| 1-2 | Beaufort Scale (For Reference Only) | 1-9 | |
| 2-1 | Inspection and Maintenance Table | 2-3 | |
| 4-1 | Skyguard Function Table | 4-11 | |
| 4-2 | Decal Legend | 4-23 | |
| 6-1 | Operating Specifications | 6-1 | |
| 6-2 | Reach Specifications | 6-2 | |
| 6-3 | Dimensional Data | 6-3 | |
| 6-4 | Chassis Specifications | 6-3 | |
| 6-5 | Component Weights | 6-4 | |
| 6-6 | Capacities | 6-4 | |
| 6-7 | Tires | 6-4 | |
| 6-8 | Caterpillar C2.2 | 6-5 | |
| 6-9 | Deutz TCD2.9L4 | 6-5 | |
| 6-10 | Deutz D2011L03 | 6-6 | |
| 6-11 | GM 3.0L | 6-6 | |
| 6-12 | Hydraulic Oil | 6-7 | |
| 6-13 | Mobilfluid 424 Specs | 6-7 | |
| 6-14 | Mobil DTE 13M Specs | 6-8 | |
| 6-15 | UCon Hydrolube HP-5046 | 6-8 | |
| 6-16 | Mobil EAL H 46 Specs | 6-9 | |
| 6-17 | Exxon Univis HVI 26 Specs | 6-9 | |
| 6-18 | Quintolubric 888-46 | 6-10 | |
| 6-19 | Lubrication Specifications | 6-21 | |
| 6-20 | Wheel Torque Chart | 6-36 | |
| 7-1 | Inspection and Repair Log | 7-1 | |

LIST OF TABLES

TABLE NUMBER - TITLE

PAGE

TABLE NUMBER - TITLE

PAGE

This Page Left Blank Intentionally.

SECTION 1. SAFETY PRECAUTIONS

1.1 GENERAL

This section outlines the necessary precautions for proper and safe machine usage and maintenance. It is mandatory that a daily routine is established based on the content of this manual to promote proper machine usage. A maintenance program, using the information provided in this manual and the Service and Maintenance Manual, must also be established by a qualified person and must be followed to ensure that the machine is safe to operate.

The owner/user/operator/lessor/lessee of the machine must not accept operating responsibility until this manual has been read, training is accomplished, and operation of the machine has been completed under the supervision of an experienced and qualified operator.

This section contains the responsibilities of the owner, user, operator, lessor, and lessee concerning safety, training, inspection, maintenance, application, and operation. If there are any questions with regard to safety, training, inspection, maintenance, application, and operation, please contact JLG Industries, Inc. ("JLG").

WARNING

FAILURE TO COMPLY WITH THE SAFETY PRECAUTIONS LISTED IN THIS MANUAL COULD RESULT IN MACHINE DAMAGE, PROPERTY DAMAGE, PERSONAL INJURY OR DEATH.

1.2 PRE-OPERATION

Operator Training and Knowledge

- The Operation and Safety Manual must be read and understood in its entirety before operating the machine. For clarification, questions, or additional information regarding any portions of this manual, contact JLG Industries, Inc.

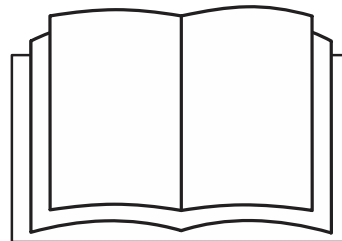

SECTION 1 - SAFETY PRECAUTIONS

- An operator must not accept operating responsibilities until adequate training has been given by competent and authorized persons.
- Allow only those authorized and qualified personnel to operate the machine who have demonstrated that they understand the safe and proper operation and maintenance of the unit.
- Read, understand, and obey all DANGERS, WARNINGS, CAUTIONS, and operating instructions on the machine and in this manual.
- Ensure that the machine is to be used in a manner which is within the scope of its intended application as determined by JLG.
- All operating personnel must be familiar with the emergency controls and emergency operation of the machine as specified in this manual.
- Read, understand, and obey all applicable employer, local, and governmental regulations as they pertain to your utilization and application of the machine.

Workplace Inspection

- Precautions to avoid all hazards in the work area must be taken by the user before and during operation of the machine.
- Do not operate or raise the platform from a position on trucks, trailers, railway cars, floating vessels, scaffolds or other equipment unless the application is approved in writing by JLG.
- Before operation, check work area for overhead hazards such as electric lines, bridge cranes, and other potential overhead obstructions.
- Check operating surfaces for holes, bumps, drop-offs, obstructions, debris, concealed holes, and other potential hazards.
- Check the work area for hazardous locations. Do not operate the machine in hazardous environments unless approved for that purpose by JLG.
- Ensure that the ground conditions are adequate to support the maximum tire load indicated on the tire load decals located on the chassis adjacent to each wheel. Do not travel on unsupported surfaces.

Machine Inspection

- Do not operate this machine until the inspections and functional checks as specified in Section 2 of this manual have been performed.
- Do not operate this machine until it has been serviced and maintained according to the maintenance and inspection requirements as specified in the machine's Service and Maintenance Manual.
- Ensure all safety devices are operating properly. Modification of these devices is a safety violation.

WARNING

MODIFICATION OR ALTERATION OF AN AERIAL WORK PLATFORM SHALL BE MADE ONLY WITH PRIOR WRITTEN PERMISSION FROM THE MANUFACTURER.

- Do not operate any machine on which the safety or instruction placards or decals are missing or illegible.
- Check the machine for modifications to original components. Ensure that any modifications have been approved by JLG.
- Avoid accumulation of debris on platform floor. Keep mud, oil, grease, and other slippery substances from footwear and platform floor.

1.3 OPERATION

General

- Machine operation requires your full attention. Bring the machine to a full stop before using any device, i.e. cell phones, two-way radios, etc. that will distract your attention from safely operating the machine.
- Do not use the machine for any purpose other than positioning personnel, their tools, and equipment.
- Before operation, the user must be familiar with the machine capabilities and operating characteristics of all functions.
- Never operate a malfunctioning machine. If a malfunction occurs, shut down the machine. Remove the unit from service and notify the proper authorities.
- Do not remove, modify, or disable any safety devices.
- Never slam a control switch or lever through neutral to an opposite direction. Always return switch to neutral and stop before moving the switch to the next function. Operate controls with slow and even pressure.
- Do not allow personnel to tamper with or operate the machine from the ground with personnel in the platform, except in an emergency.

SECTION 1 - SAFETY PRECAUTIONS

- Do not carry materials directly on platform railing unless approved by JLG.
- When two or more persons are in the platform, the operator shall be responsible for all machine operations.
- Always ensure that power tools are properly stowed and never left hanging by their cord from the platform work area.
- When driving, always position boom over rear axle in line with the direction of travel. Remember, if boom is over the front axle, steer and drive functions will be reversed.
- Do not assist a stuck or disabled machine by pushing or pulling except by pulling at the chassis tie-down lugs.
- Fully lower platform and shut off all power before leaving machine.
- Remove all rings, watches, and jewelry when operating machine. Do not wear loose fitting clothing or long hair unrestrained which may become caught or entangled in equipment.
- Persons under the influence of drugs or alcohol or who are subject to seizures, dizziness or loss of physical control must not operate this machine.

- Hydraulic cylinders are subject to thermal expansion and contraction. This may result in changes to the boom and/or platform position while the machine is stationary. Factors affecting thermal movement can include the length of time the machine will remain stationary, hydraulic oil temperature, ambient air temperature, and boom and platform position.

Trip and Fall Hazards

- During operation, occupants in the platform must wear a full body harness with a lanyard attached to an authorized lanyard anchorage point. Attach only one (1) lanyard per lanyard anchorage point..

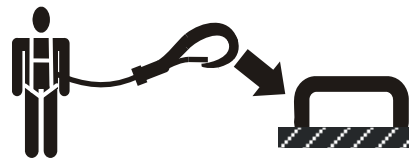

- Enter and exit only through gate area. Use extreme caution when entering or leaving platform. Ensure that the platform assembly is fully lowered. Face the machine when entering or leaving the platform. Always maintain “three point contact” with the machine, using two hands and one foot or two feet and one hand at all times during entry and exit.

- Before operating the machine, make sure all gates are closed and fastened in their proper position.

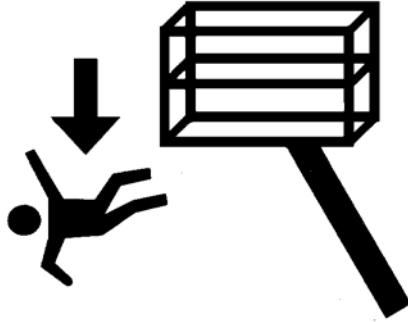

- Keep both feet firmly positioned on the platform floor at all times. Never position ladders, boxes, steps, planks, or similar items on unit to provide additional reach for any purpose.
- Keep oil, mud, and slippery substances cleaned from footwear and the platform floor.

Electrocution Hazards

- This machine is not insulated and does not provide protection from contact or proximity to electrical current.

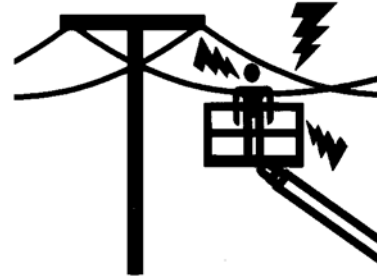

SECTION 1 - SAFETY PRECAUTIONS

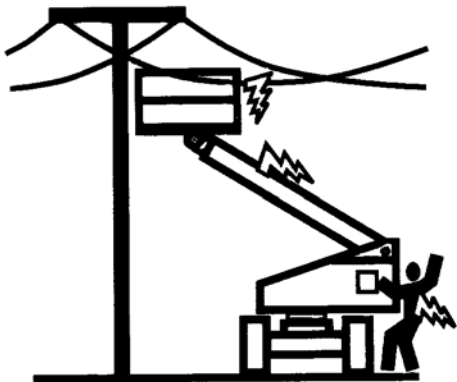

- Maintain distance from electrical lines, apparatus, or any energized (exposed or insulated) parts according to the Minimum Approach Distance (MAD) as shown in Table 1-1.
- Allow for machine movement and electrical line swaying.

Table 1-1. Minimum Approach Distances (M.A.D.)

| Voltage Range (Phase to Phase) | MINIMUM APPROACH DISTANCE in Feet (Meters) |
|---|---|
| 0 to 50 KV | 10 (3) |
| Over 50KV to 200 KV | 15 (5) |
| Over 200 KV to 350 KV | 20 (6) |
| Over 350 KV to 500 KV | 25 (8) |
| Over 500 KV to 750 KV | 35 (11) |
| Over 750 KV to 1000 KV | 45 (14) |

NOTE: *This requirement shall apply except where employer, local or governmental regulations are more stringent.*

- Maintain a clearance of at least 10 ft. (3m) between any part of the machine and its occupants, their tools, and their equipment from any electrical line or apparatus carrying up to 50,000 volts. One foot additional clearance is required for every additional 30,000 volts or less.

- The minimum approach distance may be reduced if insulating barriers are installed to prevent contact, and the barriers are rated for the voltage of the line being guarded. These barriers shall not be part of (or attached to) the machine. The minimum approach distance shall be reduced to a distance within the designed working dimensions of the insulating barrier. This determination shall be made by a qualified person in accordance with the employer, local, or governmental requirements for work practices near energized equipment

⚠ DANGER

DO NOT MANEUVER MACHINE OR PERSONNEL INSIDE PROHIBITED ZONE (MAD). ASSUME ALL ELECTRICAL PARTS AND WIRING ARE ENERGIZED UNLESS KNOWN OTHERWISE.

Tipping Hazards

- The user must be familiar with the surface before driving. Do not exceed the allowable sideslope and grade while driving.

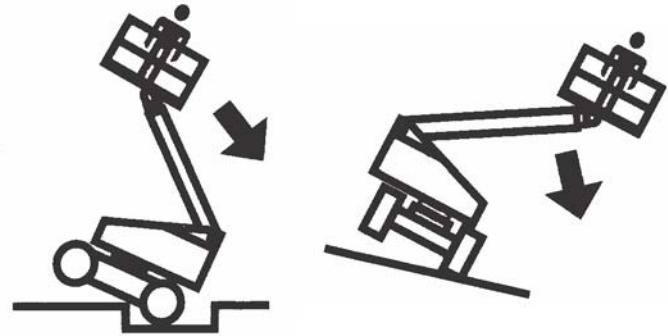

- Do not elevate platform or drive with platform elevated while on or near a sloping, uneven, or soft surface. Ensure machine is positioned on a firm, level and smooth surface before elevating platform or driving with the platform in the elevated position.
- Before driving on floors, bridges, trucks, and other surfaces, check allowable capacity of the surfaces.

SECTION 1 - SAFETY PRECAUTIONS

- Never exceed the maximum work load as specified on the platform. Keep all loads within the confines of the platform, unless authorized by JLG.
- Keep the chassis of the machine a minimum of 2 ft. (0.6m) from holes, bumps, drop-offs, obstructions, debris, concealed holes, and other potential hazards at the ground level.
- Do not push or pull any object with the boom.
- Never attempt to use the machine as a crane. Do not tie-off machine to any adjacent structure. Never attach wire, cable, or any similar items to platform.
- Do not operate the machine when wind conditions exceed 28 mph (12.5 m/s). Refer to Table 1-2, Beaufort Scale (For Reference Only).
- Do not increase the surface area of the platform or the load. Increase of the area exposed to the wind will decrease stability.
- Do not increase the platform size with unauthorized deck extensions or attachments.
- If boom assembly or platform is in a position that one or more wheels are off the ground, all persons must be removed before attempting to stabilize the machine. Use cranes, forklift trucks, or other appropriate equipment to stabilize machine.

NOTICE

DO NOT OPERATE THE MACHINE WHEN WIND CONDITIONS EXCEED 28 MPH (12.5 M/S).

Table 1-2. Beaufort Scale (For Reference Only)

| Beaufort Number | Wind Speed | | Description | Land Conditions |
|-----------------|------------|-----------|-------------------------|---|
| | mph | m/s | | |
| 0 | 0 | 0-0.2 | Calm | Calm. Smoke rises vertically |
| 1 | 1-3 | 0.3-1.5 | Light air | Wind motion visible in smoke |
| 2 | 4-7 | 1.6-3.3 | Light breeze | Wind felt on exposed skin. Leaves rustle |
| 3 | 8-12 | 3.4-5.4 | Gentle breeze | Leaves and smaller twigs in constant motion |
| 4 | 13-18 | 5.5-7.9 | Moderate breeze | Dust and loose paper raised. Small branches begin to move. |
| 5 | 19-24 | 8.0-10.7 | Fresh breeze | Smaller trees sway. |
| 6 | 25-31 | 10.8-13.8 | Strong breeze | Large branches in motion. Flags waving near horizontal. Umbrella use becomes difficult. |
| 7 | 32-38 | 13.9-17.1 | Near Gale/Moderate Gale | Whole trees in motion. Effort needed to walk against the wind. |
| 8 | 39-46 | 17.2-20.7 | Fresh Gale | Twigs broken from trees. Cars veer on road. |
| 9 | 47-54 | 20.8-24.4 | Strong Gale | Light structure damage. |

Crushing and Collision Hazards

- Approved head gear must be worn by all operating and ground personnel.
- Check work area for clearances overhead, on sides, and bottom of platform when lifting or lowering platform, and driving.

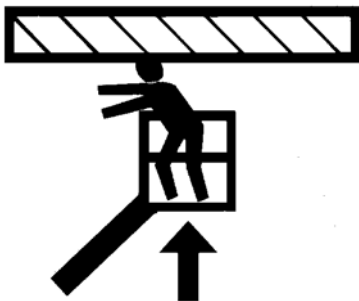

- During operation, keep all body parts inside platform railing.
- Use the boom functions, not the drive function, to position the platform close to obstacles.
- Always post a lookout when driving in areas where vision is obstructed.

- Keep non-operating personnel at least 6 ft. (1.8m) away from machine during all driving and swing operations.
- Under all travel conditions, the operator must limit travel speed according to conditions of ground surface, congestion, visibility, slope, location of personnel, and other factors which may cause collision or injury to personnel.
- Be aware of stopping distances in all drive speeds. When driving in high speed, switch to low speed before stopping. Travel grades in low speed only.
- Do not use high speed drive in restricted or close quarters or when driving in reverse.
- Exercise extreme caution at all times to prevent obstacles from striking or interfering with operating controls and persons in the platform.
- Be sure that operators of other overhead and floor level machines are aware of the aerial work platform's presence. Disconnect power to overhead cranes.
- Warn personnel not to work, stand, or walk under a raised boom or platform. Position barricades on floor if necessary.

1.4 TOWING, LIFTING, AND HAULING

- Never allow personnel in platform while towing, lifting, or hauling.
- This machine should not be towed, except in the event of emergency, malfunction, power failure, or loading/unloading. Refer to the Emergency Procedures section of this manual for emergency towing procedures.
- Ensure boom is in the stowed position and the turntable locked prior to towing, lifting or hauling. The platform must be completely empty of tools.
- When lifting machine, lift only at designated areas of the machine. Lift the unit with equipment of adequate capacity.
- Refer to the Machine Operation section of this manual for lifting information.

1.5 MAINTENANCE

This sub-section contains general safety precautions which must be observed during maintenance of this machine. Additional precautions to be observed during machine maintenance are inserted at the appropriate points in this manual and in the Service and Maintenance Manual. It is of utmost importance that maintenance personnel pay strict attention to these precautions to avoid possible injury to personnel or damage to the machine or property. A maintenance program must be established by a qualified person and must be followed to ensure that the machine is safe.

Maintenance Hazards

- Shut off power to all controls and ensure that all moving parts are secured from inadvertent motion prior to performing any adjustments or repairs.
- Never work under an elevated platform until it has been fully lowered to the full down position, if possible, or otherwise supported and restrained from movement with appropriate safety props, blocking, or overhead supports.
- DO NOT attempt to repair or tighten any hydraulic hoses or fittings while the machine is powered on or when the hydraulic system is under pressure.
- Always relieve hydraulic pressure from all hydraulic circuits before loosening or removing hydraulic components.

SECTION 1 - SAFETY PRECAUTIONS

- DO NOT use your hand to check for leaks. Use a piece of cardboard or paper to search for leaks. Wear gloves to help protect hands from spraying fluid.



- Ensure replacement parts or components are identical or equivalent to original parts or components.
- Never attempt to move heavy parts without the aid of a mechanical device. Do not allow heavy objects to rest in an unstable position. Ensure adequate support is provided when raising components of the machine.

- Do not use machine as a ground for welding.
- When performing welding or metal cutting operations, precautions must be taken to protect the chassis from direct exposure to weld and metal cutting spatter.
- Do not refuel the machine with the engine running.
- Use only approved non-flammable cleaning solvents.
- Do not replace items critical to stability, such as batteries or solid tires, with items of different weight or specification. Do not modify unit in any way to affect stability.
- Refer to the Service and Maintenance Manual for the weights of critical stability items.

⚠ WARNING

MODIFICATION OR ALTERATION OF AN AERIAL WORK PLATFORM SHALL BE MADE ONLY WITH PRIOR WRITTEN PERMISSION FROM THE MANUFACTURER.

Battery Hazards

- Always disconnect batteries when servicing electrical components or when performing welding on the machine.
- Do not allow smoking, open flame, or sparks near battery during charging or servicing.
- Do not contact tools or other metal objects across the battery terminals.
- Always wear hand, eye, and face protection when servicing batteries. Ensure that battery acid does not come in contact with skin or clothing.

CAUTION

BATTERY FLUID IS HIGHLY CORROSIVE. AVOID CONTACT WITH SKIN AND CLOTHING AT ALL TIMES. IMMEDIATELY RINSE ANY CONTACTED AREA WITH CLEAN WATER AND SEEK MEDICAL ATTENTION.

- Charge batteries only in a well ventilated area.
- Avoid overfilling the battery fluid level. Add distilled water to batteries only after the batteries are fully charged.

SECTION 2. USER RESPONSIBILITIES, MACHINE PREPARATION, AND INSPECTION

2.1 PERSONNEL TRAINING

The aerial platform is a personnel handling device; so it is necessary that it be operated and maintained only by trained personnel.

Persons under the influence of drugs or alcohol or who are subject to seizures, dizziness or loss of physical control must not operate this machine.

Operator Training

Operator training must cover:

1. Use and limitations of the controls in the platform and at the ground, emergency controls and safety systems.
2. Control labels, instructions, and warnings on the machine.
3. Rules of the employer and government regulations.
4. Use of approved fall protection device.
5. Enough knowledge of the mechanical operation of the machine to recognize a malfunction or potential malfunction.

6. The safest means to operate the machine where overhead obstructions, other moving equipment, and obstacles, depressions, holes, dropoffs.
7. Means to avoid the hazards of unprotected electrical conductors.
8. Specific job requirements or machine application.

Training Supervision

Training must be done under the supervision of a qualified person in an open area free of obstructions until the trainee has developed the ability to safely control and operate the machine.

Operator Responsibility

The operator must be instructed that he/she has the responsibility and authority to shut down the machine in case of a malfunction or other unsafe condition of either the machine or the job site.

2.2 PREPARATION, INSPECTION, AND MAINTENANCE

The following table covers the periodic machine inspections and maintenance required by JLG Industries, Inc. Consult local regulations for further requirements for aerial work platforms. The frequency of inspections and maintenance must be increased as necessary when the machine is used in a harsh or hostile environment, if the machine is used with increased frequency, or if the machine is used in a severe manner.

NOTICE

JLG INDUSTRIES, INC. RECOGNIZES A FACTORY TRAINED SERVICE TECHNICIAN AS A PERSON WHO HAS SUCCESSFULLY COMPLETED THE JLG SERVICE TRAINING SCHOOL FOR THE SPECIFIC JLG PRODUCT MODEL.

SECTION 2 - USER RESPONSIBILITIES, MACHINE PREPARATION, AND INSPECTION

Table 2-1. Inspection and Maintenance Table

| Type | Frequency | Primary Responsibility | Service Qualification | Reference |
|--------------------------------------|---|------------------------|--|---|
| Pre-Start Inspection | Before using each day; or whenever there's an Operator change. | User or Operator | User or Operator | Operator and Safety Manual |
| Pre-Delivery Inspection (See Note) | Before each sale, lease, or rental delivery. | Owner, Dealer, or User | Qualified JLG Mechanic | Service and Maintenance Manual and applicable JLG inspection form |
| Frequent Inspection (See Note) | In service for 3 months or 150 hours, whichever comes first; or Out of service for a period of more than 3 months; or Purchased used. | Owner, Dealer, or User | Qualified JLG Mechanic | Service and Maintenance Manual and applicable JLG inspection form |
| Annual Machine Inspection (See Note) | Annually, no later than 13 months from the date of prior inspection. | Owner, Dealer, or User | Factory Trained Service Technician (Recommended) | Service and Maintenance Manual and applicable JLG inspection form |
| Preventative Maintenance | At intervals as specified in the Service and Maintenance Manual. | Owner, Dealer, or User | Qualified JLG Mechanic | Service and Maintenance Manual |

NOTE: Inspection forms are available from JLG. Use the Service and Maintenance Manual to perform inspections.

SECTION 2 - USER RESPONSIBILITIES, MACHINE PREPARATION, AND INSPECTION

Pre-Start Inspection

The Pre-Start Inspection should include each of the following:

1. **Cleanliness** – Check all surfaces for leakage (oil, fuel, or battery fluid) or foreign objects. Report any leakage to the proper maintenance personnel.
2. **Structure** - Inspect the machine structure for dents, damage, weld or parent metal cracks or other discrepancies.

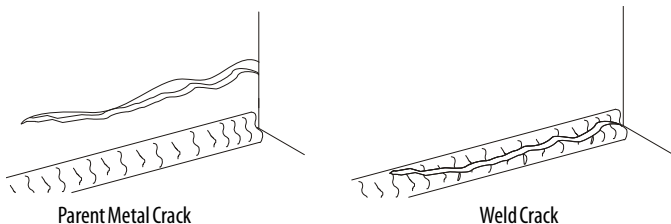

3. **Decals and Placards** – Check all for cleanliness and legibility. Make sure none of the decals and placards are missing. Make sure all illegible decals and placards are cleaned or replaced.

4. **Operation and Safety Manuals** – Make sure a copy of the Operator and Safety Manual, AEM Safety Manual (ANSI markets only), and ANSI Manual of Responsibilities (ANSI markets only) is enclosed in the weather resistant storage container.
5. **“Walk-Around” Inspection** – Refer to Figure 2-3. and Figure 2-4.
6. **Battery** – Charge as required.
7. **Fuel** (Combustion Engine Powered Machines) – Add the proper fuel as necessary.
8. **Engine Oil Supply** - Ensure the engine oil level is at the Full mark on the dipstick and the filler cap is secure.
9. **Hydraulic Oil** – Check the hydraulic oil level. Ensure hydraulic oil is added as required.
10. **Accessories/Attachments** - Reference the Operator and Safety Manual of each attachment for accessory installed upon the machine for specific inspection, operation, and maintenance instructions.

SECTION 2 - USER RESPONSIBILITIES, MACHINE PREPARATION, AND INSPECTION

- 11. Function Check** – Once the “Walk-Around” Inspection is complete, perform a functional check of all systems in an area free of overhead and ground level obstructions. Refer to Section 4 for more specific instructions.



IF THE MACHINE DOES NOT OPERATE PROPERLY, TURN OFF THE MACHINE IMMEDIATELY! REPORT THE PROBLEM TO THE PROPER MAINTENANCE PERSONNEL. DO NOT OPERATE THE MACHINE UNTIL IT IS DECLARED SAFE FOR OPERATION.

Function Check

Perform the Function Check as follows:

- From the ground control panel with no load in the platform:
 - Check that all guards protecting the switches or locks are in place;
 - Operate all functions and check boom limit switches; drive speed should switch to creep mode if lower boom is elevated or main boom is above horizontal.
 - Check auxiliary power (or manual descent);
 - Ensure that all machine functions are disabled when the Emergency Stop Button is activated.
 - Ensure all boom functions stop when the function enable switch is released.
- From the platform control console:
 - Ensure that the control console is firmly secured in the proper location;
 - Check that all guards protecting the switches or locks are in place;
 - Operate all functions and check all limiting and cut-out switches;
 - Ensure that all machine functions are disabled when the Emergency Stop Button is pushed in.
 - Ensure that all machine functions stop when the foot-switch is released.
- With the platform in the transport (stowed) position:
 - Drive the machine on a grade, not to exceed the rated gradeability, and stop to ensure the brakes hold;
 - Check that the tilt indicator is illuminated to ensure proper operation.

SECTION 2 - USER RESPONSIBILITIES, MACHINE PREPARATION, AND INSPECTION

SkyGuard Function Test

From the Platform Console:

Test the SkyGuard feature by operating the telescope out functions and then activating the SkyGuard sensor. The telescope out function will stop and the telescope in function will operate for a short duration and the horn will sound until the SkyGuard sensor and footswitch are disengaged.

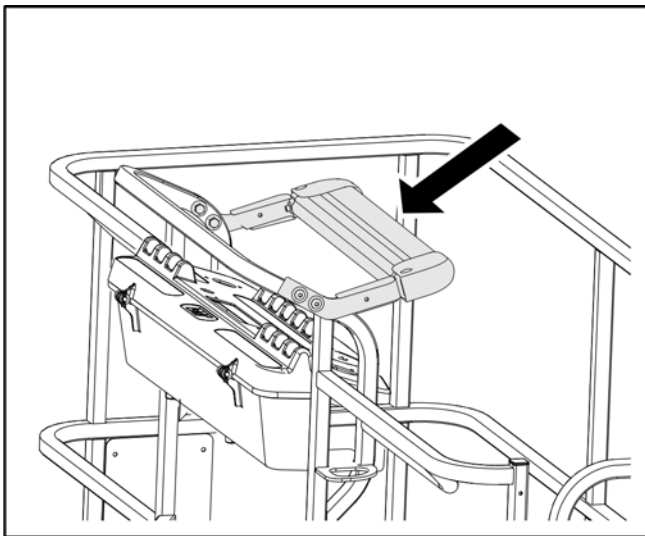

NOTE: If the machine is equipped with both SkyGuard and Soft Touch, functions will not reverse, only stop.

NOTE: If equipped, ensure the blue beacon illuminates when SkyGuard is activated.

Disengage the SkyGuard sensor, release controls, recycle the foot switch, make sure normal operation is available.

If SkyGuard remains activated after function reversal or cutout, depress and hold the SkyGuard Override Switch to allow normal use of machine functions until the SkyGuard sensor is disengaged.

SECTION 2 - USER RESPONSIBILITIES, MACHINE PREPARATION, AND INSPECTION

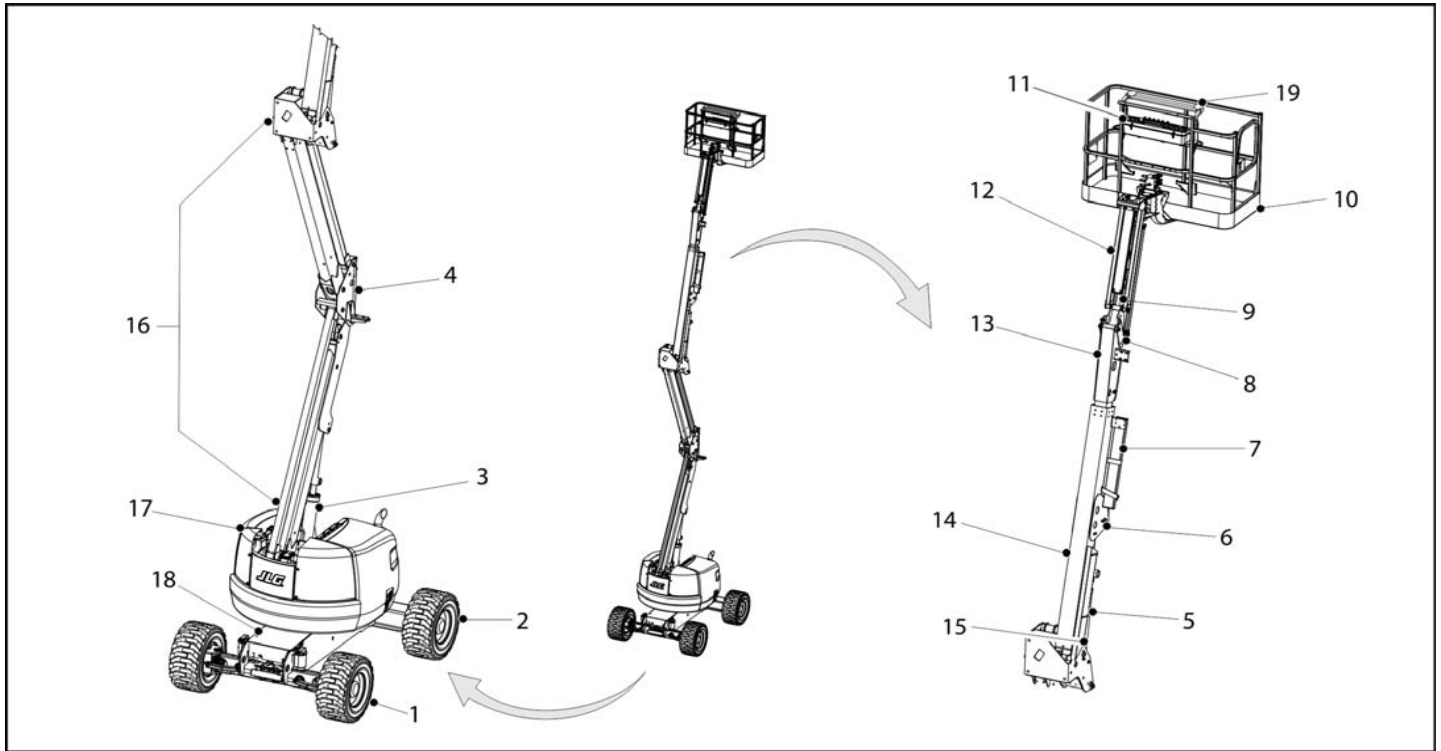

Figure 2-1. Basic Nomenclature - Sheet 1 of 2

SECTION 2 - USER RESPONSIBILITIES, MACHINE PREPARATION, AND INSPECTION

1. Front Drive/Steer Wheels
2. Rear Drive Wheels
3. Tower Lift Cylinder
4. Lower Upright
5. Main Lift Cylinder
6. Main Boom Assembly
7. Power Track
8. Level Cylinder
9. Jib Cylinder
10. Platform
11. Platform Console
12. Jib
13. Fly Boom Section
14. Base Boom Section
15. Master Cylinder
16. Tower Boom
17. Turntable
18. Frame
19. SkyGuard (If Equipped)

Figure 2-2. Basic Nomenclature - Sheet 2 of 2

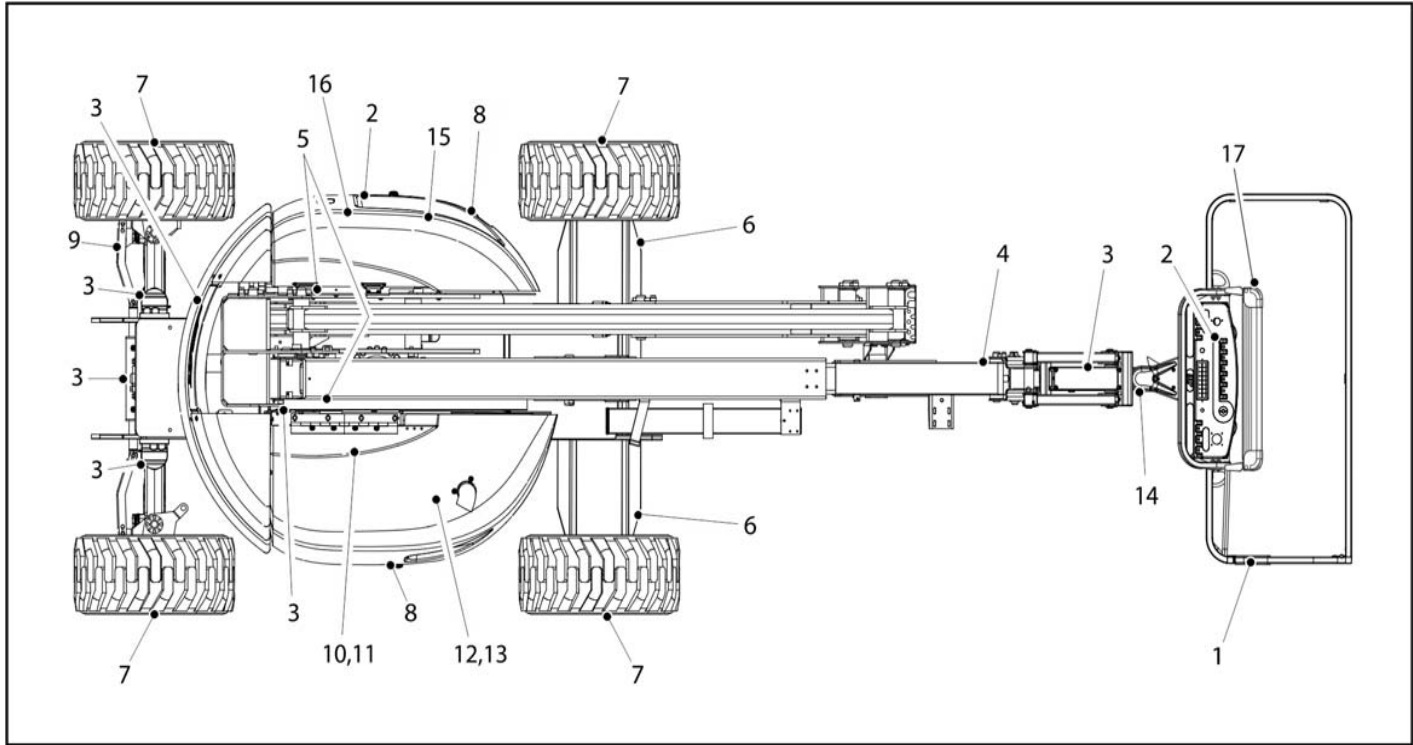

Figure 2-3. Daily Walk-Around Inspection - Sheet 1 of 3

SECTION 2 - USER RESPONSIBILITIES, MACHINE PREPARATION, AND INSPECTION

GENERAL

Begin the "Walk-Around Inspection" at Item 1, as noted on the diagram. Continue to the right (counterclockwise viewed from top) checking each item in sequence for the conditions listed in the following checklist.

WARNING

TO AVOID POSSIBLE INJURY, BE SURE MACHINE POWER IS OFF.

DO NOT OPERATE MACHINE UNTIL ALL MALFUNCTIONS HAVE BEEN CORRECTED.

INSPECTION NOTE: *On all components, make sure there are no loose or missing parts, that they are securely fastened, and no visible damage, leaks or excessive wear exists in addition to any other criteria mentioned.*

- 1. Platform Assembly and Gate** - Footswitch works properly, not modified, disabled or blocked. Gate latch, stop, and hinges in working condition.
- 2. Platform & Ground Control Consoles** - Switches and levers return to neutral, decals/placards secure and legible, control markings legible.
- 3. All Hydraulic Cylinders** - No visible damage; pivot pins and hydraulic hoses undamaged, not leaking.
- 4. Boom Sections/Uprights/Turntable** - See Inspection Note.
- 5. Boom Limit Switches** - Switches operate properly.
- 6. Drive Motor, Brake, and Hub** - No evidence of leakage.
- 7. Wheel/Tire Assemblies** - Properly secured, no missing lug nuts. Inspect for worn tread, cuts, tears or other discrepancies. Inspect wheels for damage and corrosion.
- 8. Hood Assemblies** - See Inspection Note.

Figure 2-4. Daily Walk-Around Inspection - Sheet 2 of 3

SECTION 2 - USER RESPONSIBILITIES, MACHINE PREPARATION, AND INSPECTION

- 9. Tie Rod Ends and Steering Spindles** - See Inspection Note.
- 10. Turntable Bearing** - Evidence of proper lubrication. No evidence of loose bolts or looseness between bearing and machine.
- 11. Swing Motor and Worm Gear** - Evidence of proper lubrication; No evidence of damage.
- 12. Auxiliary Hydraulic Pump** - See Inspection Note.
- 13. Main Hydraulic Pump** - See Inspection Note.
- 14. Platform Rotator** - See Inspection Note.
- 15. Fuel Tank** - See Inspection Note.
- 16. Hydraulic Reservoir** - See Inspection Note.
- 17. SkyGuard** - See Inspection Note.

Figure 2-5. Daily Walk-Around Inspection - Sheet 3 of 3

2.3 OSCILLATING AXLE LOCKOUT TEST (IF EQUIPPED)

NOTICE

LOCKOUT SYSTEM TEST MUST BE PERFORMED QUARTERLY, ANY TIME A SYSTEM COMPONENT IS REPLACED, OR WHEN IMPROPER SYSTEM OPERATION IS SUSPECTED.

NOTE: *Ensure boom is fully retracted, lowered, and centered between drive wheels prior to beginning lockout cylinder test.*

1. Place a 6 inches (15.2 cm) high block with ascension ramp in front of left front wheel.
2. From platform control station, start engine.
3. Place the Drive control lever to the forward position and carefully drive machine up ascension ramp until left front wheel is on top of block.
4. Carefully activate Swing control lever and position boom over right side of machine.
5. With boom over right side of machine, place Drive control lever to Reverse and drive machine off of block and ramp.
6. Have an assistant check to see that left front or right rear wheel remains elevated in position off of ground.
7. Carefully activate Swing control lever and return boom to stowed position (centered between drive wheels). When

boom reaches center, stowed position, lockout cylinders should release and allow wheel to rest on ground, it may be necessary to activate Drive to release cylinders.

8. Place the 6 inches (15.2 cm) high block with ascension ramp in front of right front wheel.
9. Place Drive control lever to Forward and carefully drive machine up ascension ramp until right front wheel is on top of block.
10. With boom over left side of machine, place Drive control lever to Reverse and drive machine off of block and ramp.
11. Have an assistant check to see that right front or left rear wheel remains elevated in position off of ground.
12. Carefully activate Swing control lever and return boom to stowed position (centered between drive wheels). When boom reaches center, stowed position, lockout cylinders should release and allow wheel to rest on ground, it may be necessary activate Drive to release cylinders.
13. If lockout cylinders do not function properly, have qualified personnel correct the malfunction prior to any further operation.

SECTION 3. MACHINE CONTROLS AND INDICATORS

3.1 GENERAL

NOTICE

THE MANUFACTURER HAS NO DIRECT CONTROL OVER MACHINE APPLICATION AND OPERATION. THE USER AND OPERATOR ARE RESPONSIBLE FOR CONFORMING WITH GOOD SAFETY PRACTICES.

This section provides the necessary information needed to understand control functions.

3.2 CONTROLS AND INDICATORS

NOTE: All machines are equipped with control panels that use symbols to indicate control functions. On ANSI machines refer to decal located on the control box guard in front of the control box or by the ground controls for these symbols and the corresponding functions.

NOTE: The indicator panels use different shaped symbols to alert the operator to different types of operational situations that could arise. The meaning of those symbols are explained below.

Indicates a potentially hazardous situation, which if not corrected, could result in serious injury or death. This indicator will be red.



Indicates an abnormal operating condition, which if not corrected, may result in machine interruption or damage. This indicator will be yellow.



Indicates important information regarding the operating condition, i.e. procedures essential for safe operation. This indicator will be green with the exception of the capacity indicator which will be green or yellow depending upon platform position.



⚠ WARNING

TO AVOID SERIOUS INJURY, DO NOT OPERATE MACHINE IF ANY CONTROL LEVERS OR TOGGLE SWITCHES CONTROLLING PLATFORM MOVEMENT DO NOT RETURN TO THE OFF POSITION WHEN RELEASED.

Ground Control Station



NOTE:Function Enable switch must be held down in order to operate Telescope, Swing, Tower Lift, Main Lift, Jib Lift, Platform Level Override, and Platform Rotate functions.

⚠ WARNING

DO NOT OPERATE FROM GROUND CONTROL STATION WITH PERSONNEL IN THE PLATFORM EXCEPT IN AN EMERGENCY.

PERFORM AS MANY PRE-OPERATIONAL CHECK AND INSPECTIONS FROM GROUND CONTROLS AS POSSIBLE.

1. Platform Rotate

A three position switch controls rotation of the platform.

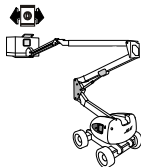

⚠ WARNING

ONLY USE THE PLATFORM LEVELING FUNCTION FOR SLIGHT LEVELING OF THE PLATFORM. INCORRECT USE COULD CAUSE THE LOAD/OCCUPANTS TO SHIFT OR FALL. FAILURE TO DO SO COULD RESULT IN DEATH OR SERIOUS INJURY.

2. Platform Leveling

A three position switch allows the operator to adjust the automatic self leveling system. This switch is used to adjust the platform level in situations such as ascending/descending a grade.

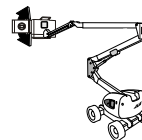

3. Jib Lift (If Equipped)

This switch provides raising and lowering of the jib.

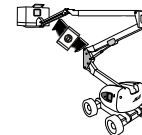

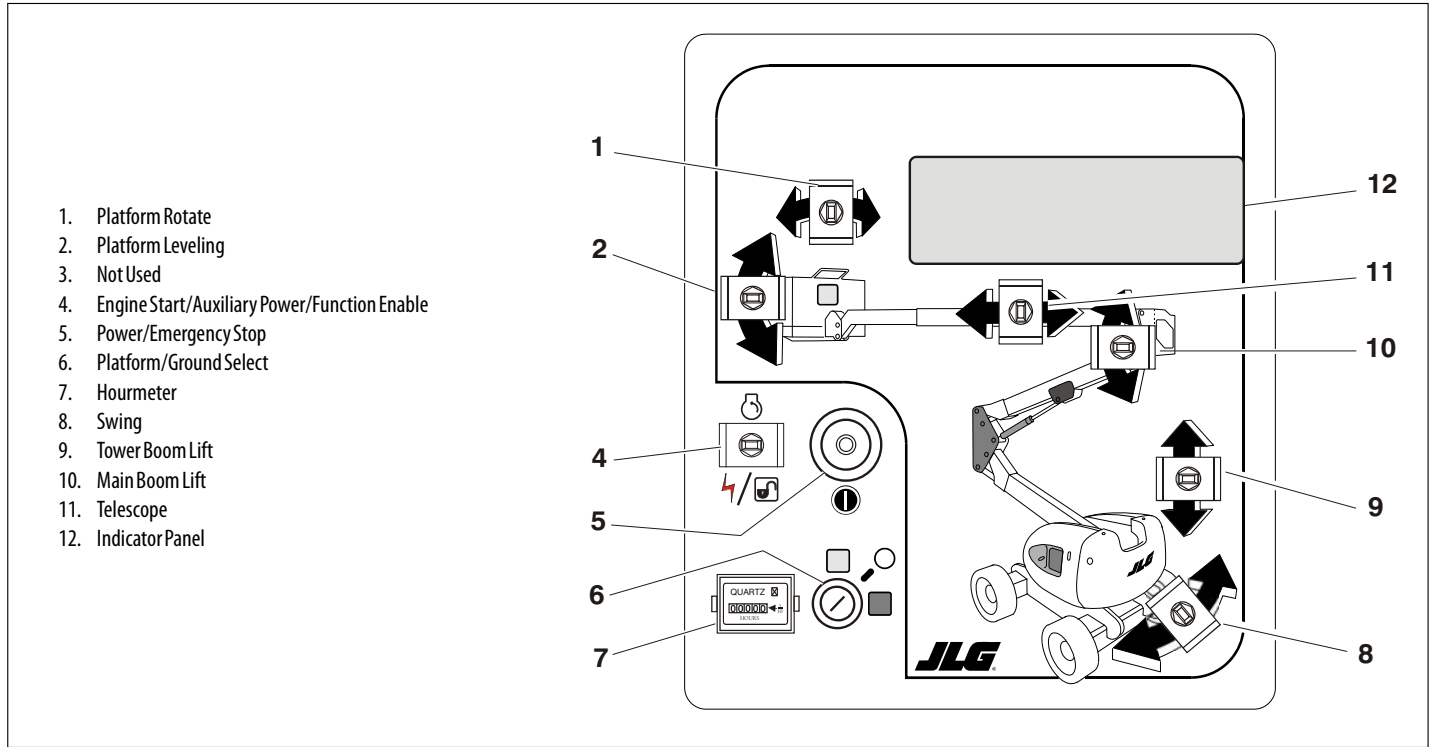

Figure 3-1. Ground Control Station - A Models

SECTION 3 - MACHINE CONTROLS AND INDICATORS

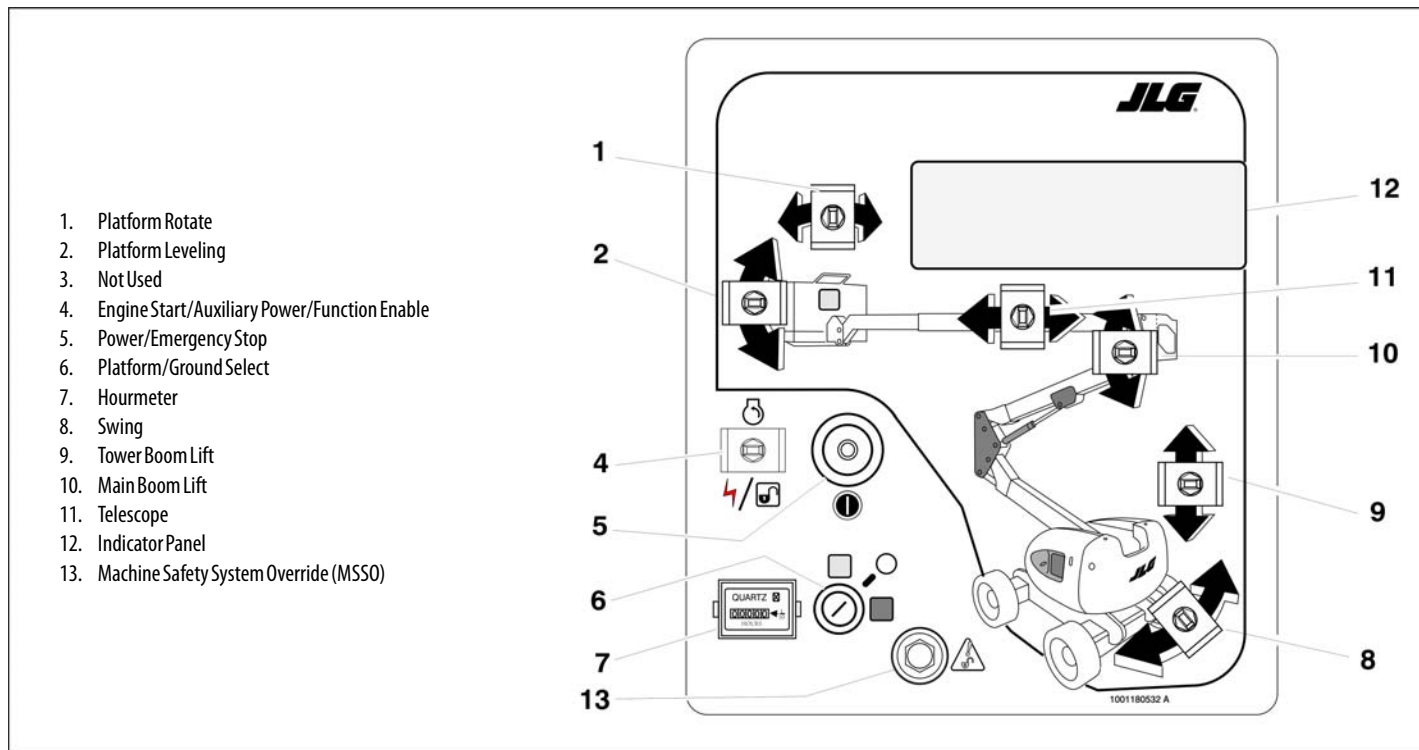

Figure 3-1. Ground Control Station - A Models with Machine Safety System Override (MSSO) (CE Only)

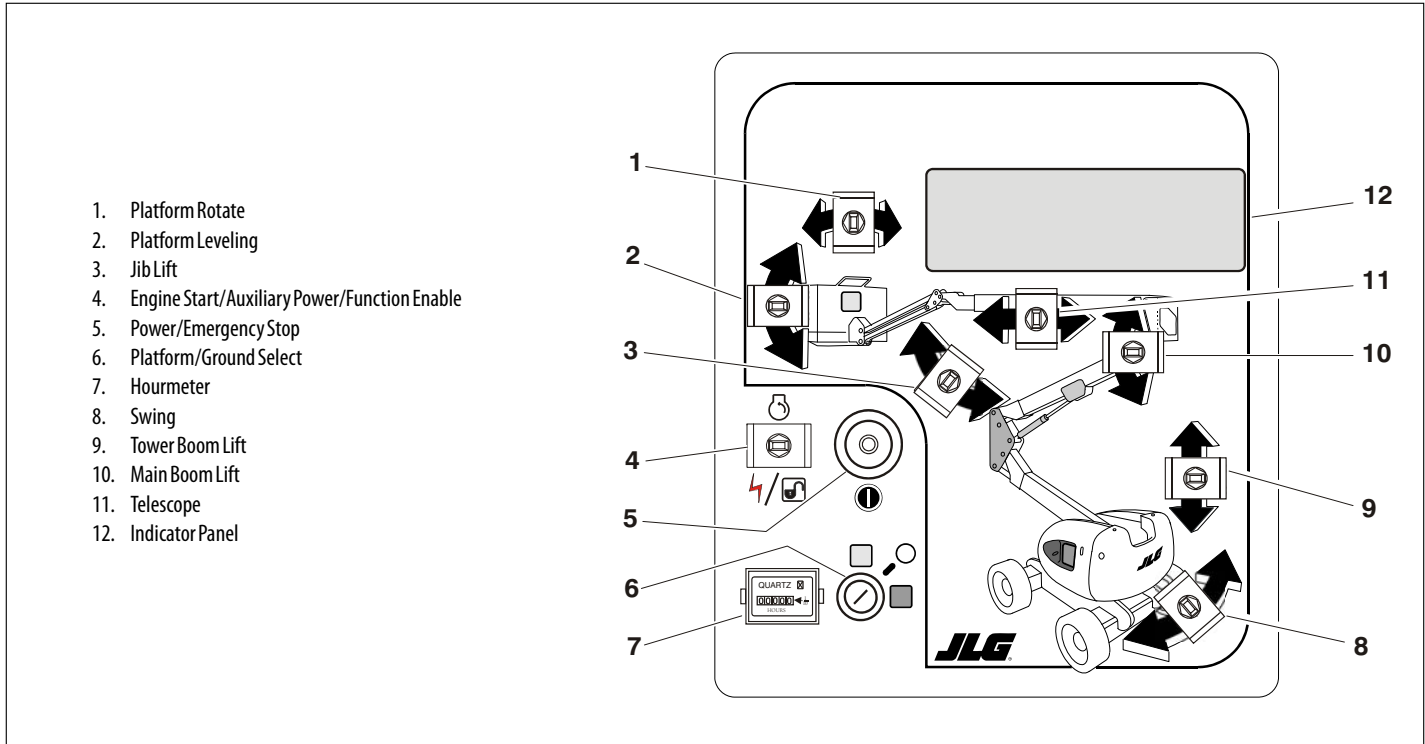

Figure 3-2. Ground Control Station - AJ Models

SECTION 3 - MACHINE CONTROLS AND INDICATORS

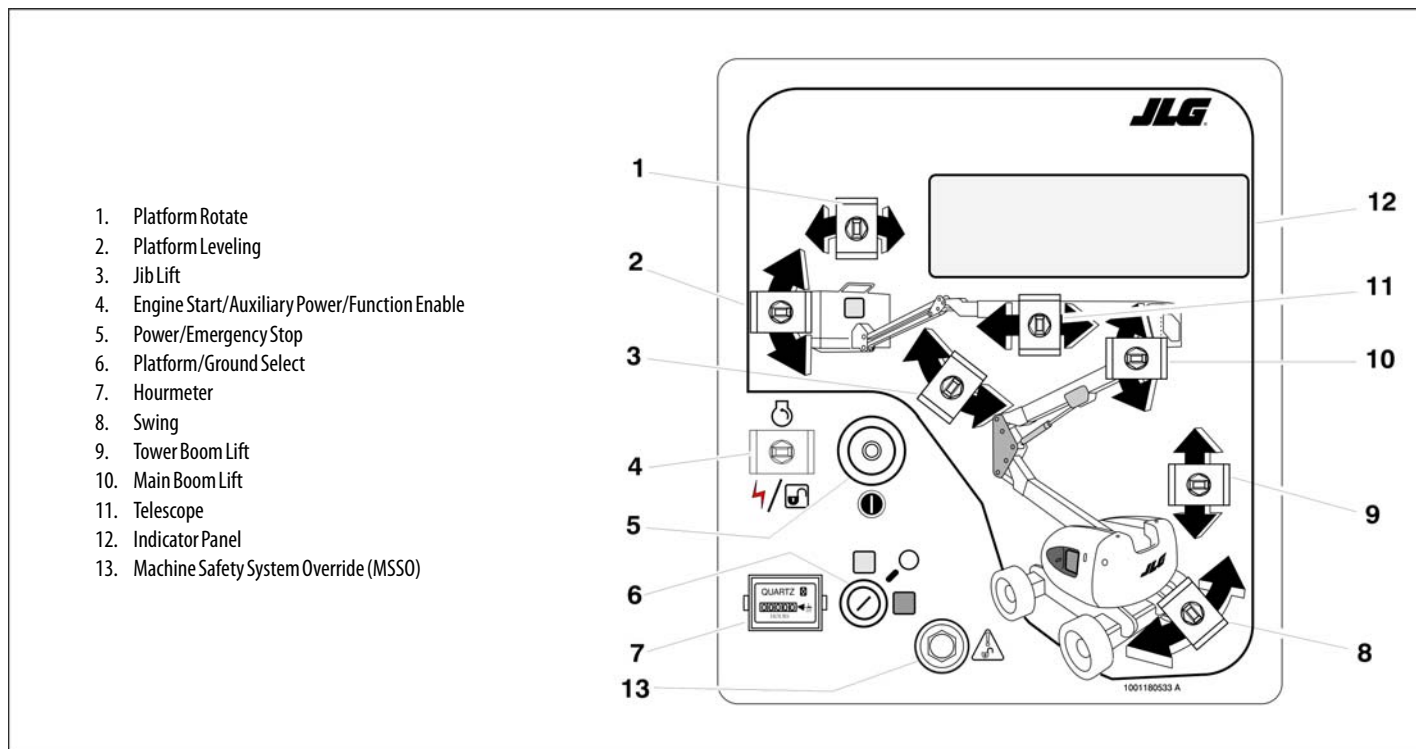

Figure 3-3. Ground Control Station - AJ Models with Machine Safety System Override (MSSO) (CE Only)

SECTION 3 - MACHINE CONTROLS AND INDICATORS

4. Engine Start/ Auxiliary Power Switch /Function Enable

To start the engine, the switch must be held "UP" until the engine starts.



To use auxiliary power, the switch must be held "DOWN" for duration of auxiliary pump use. Aux power can only be used if the engine is not running.



When the engine is running, the enable switch must be held "DOWN" to enable all boom controls when the engine is running.



NOTE: Auxiliary power only works if there is no oil pressure, and is disabled if engine is running.

5. Power/Emergency Stop

A two-position red mushroom shaped switch furnishes power to Platform/Ground Select switch when pulled out (on). When pushed in (off), power is shut off to the Platform/Ground Select switch.



NOTE: When the Platform/Ground Select Switch is in the center position, power is shut off to the controls at both operating stations. Remove the key to prevent the controls from being actuated. The key is removable in the platform position on CE specification machines. The key must be available to ground personnel in the event of an emergency.

6. Platform/Ground Select

The three position, key operated switch supplies power to the platform control console when positioned to PLATFORM. With the switch key turned to the GROUND position only ground controls are operable.



7. Hourmeter

The hourmeter registers up to 9,999.9 hours and cannot be reset.

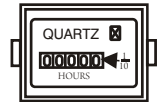

8. Swing Control

The Swing control switch provides 360 degrees non-continuous turntable rotation when positioned to the right or left.

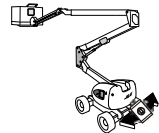

SECTION 3 - MACHINE CONTROLS AND INDICATORS

9. Tower Boom Lift

Provides raising and lowering of the Lower and Mid Booms.

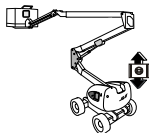

10. Main Boom Lift

Provides raising and lowering of the Main Boom.

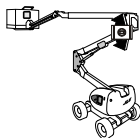

11. Telescope

Provides extension and retraction of the Main Boom.

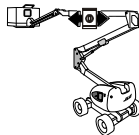

12. Machine Safety System Override (MSSO) (CE Only)

Provides emergency override of function controls that are locked out in the event of Load Sense System activation.



Ground Control Indicator Panel

1. Battery Charging Indicator

Indicates a problem in the battery or charging circuit, and service is required.



2. Engine Oil Pressure Indicator

Indicates that engine oil pressure is below normal and service is required.



3. High Engine Coolant Temperature Indicator (Liquid Cooled Engines)

Indicates that engine coolant temperature is abnormally high and service is required.



4. Engine Oil Temperature Indicator (Deutz)

Indicates that the temperature of the engine oil, which also serves as engine coolant, is abnormally high and service is required.



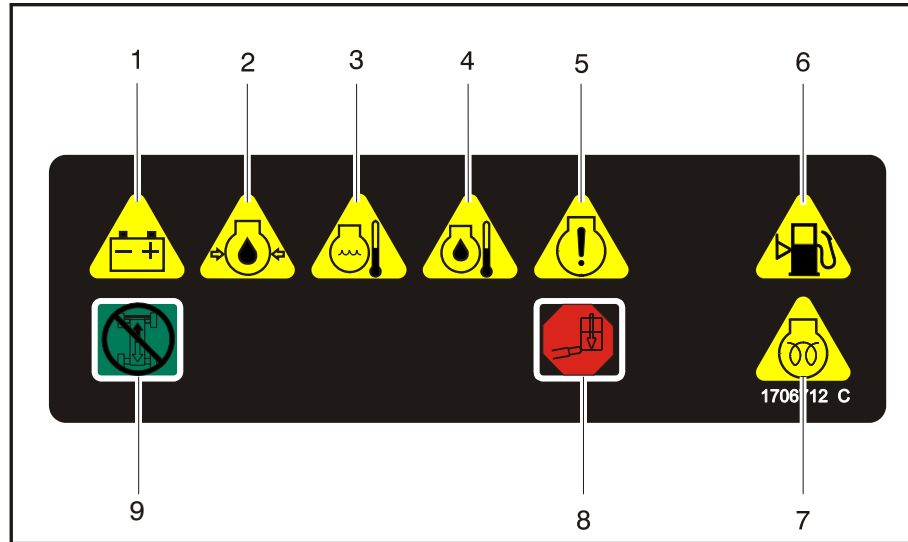

- | | |
|------------------------------|----------------------------|
| 1. Battery Charging | 6. Low Fuel |
| 2. Low Engine Oil Pressure | 7. Glow Plug Wait to Start |
| 3. High Engine Coolant Temp. | 8. Platform Overload |
| 4. Engine Oil Temp. | 9. Drive and Steer Disable |
| 5. System Distress | |

Figure 3-4. Ground Control Indicator Panel

SECTION 3 - MACHINE CONTROLS AND INDICATORS

5. System Distress Indicator

The light indicates that the JLG Control System has detected an abnormal condition and a Diagnostic Trouble Code has been set in the system memory. Refer to the Service Manual for instructions concerning the trouble codes and trouble code retrieval.



The system distress indicator light will illuminate for 2-3 seconds when the key is positioned to the on position to act as a self test.

6. Low Fuel Level Indicator

Indicates that the fuel level is 1/8 full or less.



NOTE: Refer to Fuel Reserve/Shut-Off System in Section 4 for detailed information.

7. Glow Plug Wait to Start Indicator

Indicates the glow plugs are on. The glow plugs are automatically turned on with the ignition circuit and remain on for approximately seven seconds. Start the engine only after the light goes out.



8. Platform Overload Indicator. (If Equipped)

Indicates the platform has been overloaded.



9. Drive and Steer Disable Indicator (If equipped)

Indicates the Drive and Steer Disable function has been activated.



Platform Control Station

WARNING

TO AVOID SERIOUS INJURY, DO NOT OPERATE MACHINE IF ANY CONTROL LEVERS OR TOGGLE SWITCHES CONTROLLING PLATFORM MOVEMENT DO NOT RETURN TO THE OFF OR NEUTRAL POSITION WHEN RELEASED.

1. Drive Speed Switch

(4WD Machines) - The forward position gives maximum drive speed by shifting the drive motors to minimum displacement and giving high engine when drive controller is moved.

The back position gives maximum torque for rough terrain and climbing grades by shifting the wheel motors to maximum displacement and giving high engine speed when drive controller is moved. The center position allows the machine to be driven as quietly as possible by leaving the engine at mid speed and the drive motors in maximum displacement.

(2WD Machines) - The forward position selects maximum speed by operating at high engine rpm. The backward position selects mid engine rpm.

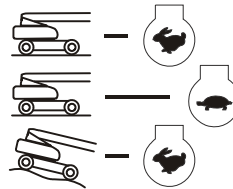

WARNING

ONLY USE THE PLATFORM LEVELING FUNCTION FOR SLIGHT LEVELING OF THE PLATFORM. INCORRECT USE COULD CAUSE THE LOAD/OCCUPANTS TO SHIFT OR FALL. FAILURE TO DO SO COULD RESULT IN DEATH OR SERIOUS INJURY.

2. Platform Leveling

A three position switch allows the operator to adjust the automatic self leveling system. This switch is used to adjust the platform level in situations such as ascending/descending a grade.



3. Horn

A push-type Horn switch supplies electrical power to an audible warning device when pressed.



4. Power/Emergency Stop

A two-position red mushroom shaped switch furnishes power to PLATFORM Controls when pulled out (on). When pushed in (off), power is shut off to the platform functions.



SECTION 3 - MACHINE CONTROLS AND INDICATORS

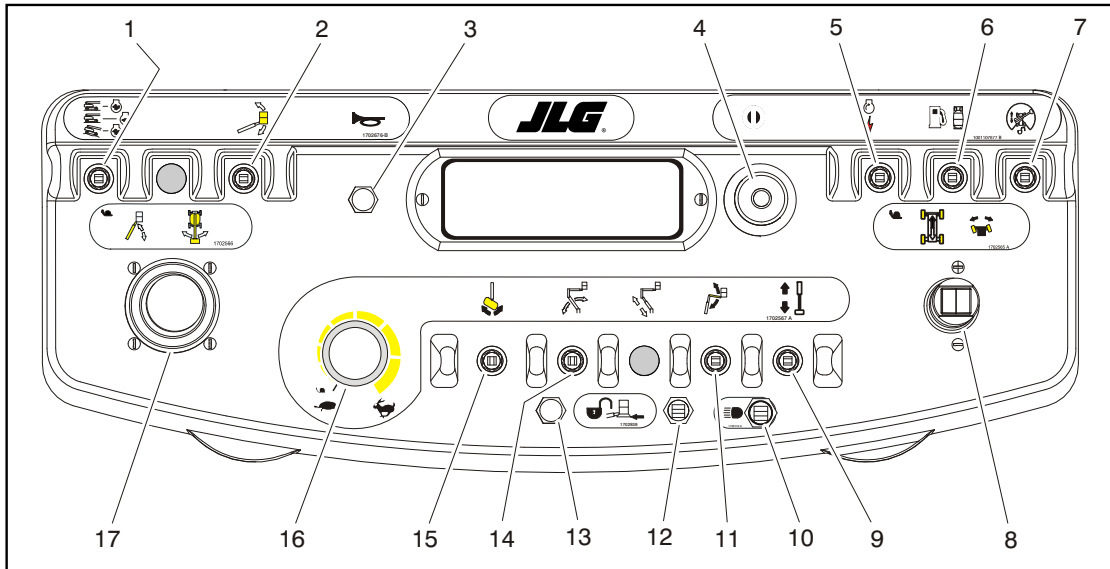

- | | | | |
|------------------------------|-------------------------------|-----------------------------------|--------------------------------|
| 1. Drive Speed/Torque Select | 6. Fuel Select | 10. Lights | 14. Tower Boom Lift |
| 2. Platform Leveling | 7. Drive Orientation Override | 11. Jib Lift | 15. Platform Rotate |
| 3. Horn | 8. Drive/Steer | 12. Soft Touch/SkyGuard Override | 16. Function Speed |
| 4. Power/Emergency Stop | 9. Telescope | 13. Soft Touch/SkyGuard Indicator | 17. Main Lift/Swing Controller |
| 5. Start/Auxiliary Power | | | |

Figure 3-5. Platform Control Console

⚠ WARNING

TO AVOID SERIOUS INJURY, DO NOT OPERATE MACHINE IF ANY CONTROL LEVERS OR TOGGLE SWITCHES CONTROLLING PLATFORM MOVEMENT DO NOT RETURN TO THE OFF OR NEUTRAL POSITION WHEN RELEASED.

5. Start/Auxiliary Power

When pushed forward, the switch energizes the starter motor to start the engine.



The Auxiliary Power control switch energizes the electrically operated hydraulic pump. (Switch must be held ON for duration of auxiliary pump use.)



The auxiliary pump functions to provide sufficient oil flow to operate the basic machine functions should the main pump or engine fail. The auxiliary pump will operate tower boom lift, tower telescope, main boom lift, main telescope and swing.

6. Fuel Select (Dual Fuel Engine Only) (If Equipped)



Moving the switch to the appropriate position selects gasoline or liquid propane fuel.

7. Drive Orientation Override



When the boom is swung over the rear tires or further in either direction, the Drive Orientation indicator will illuminate when the drive function is selected. Push and release the switch, and within 3 seconds move the Drive/Steer control to activate drive or steer. Before driving, locate the black/white orientation arrows on both the chassis and the platform controls and match the control direction arrow to the intended chassis direction.

NOTE: To operate the Drive joystick, pull up on the locking ring below the handle.

NOTE: The Drive joystick is spring loaded and will automatically return to neutral (off) position when released.

8. Drive/Steer

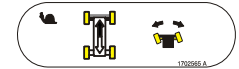

Push forward to drive forward, pull back to drive in reverse. Steering is accomplished via a thumb-activated rocker switch on the end of the steer handle.

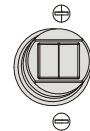

SECTION 3 - MACHINE CONTROLS AND INDICATORS

9. Telescope Control

This switch allows extension and retraction of the main boom.

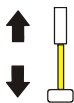

10. Lights (If Equipped)

This switch operates the chassis lights if the machine is so equipped.



11. Jib Lift (if equipped)

Provides for raising or lowering of the jib by positioning up/down.



12. Soft Touch/SkyGuard Override Switch (If equipped)

The machine can be equipped with one of three options. It may have Soft Touch, SkyGuard, or both Soft Touch and SkyGuard.

If equipped with Soft Touch, the switch enables the functions that were cut out by the Soft Touch system to operate again at creep speed, allowing the operator to move the platform away from the obstacle that caused the shutdown situation.



If equipped with SkyGuard, the switch enables functions cut out by the SkyGuard system to be operated again, allowing the operator to resume use of machine functions.



If equipped with both Soft Touch and SkyGuard, the switch operates like described above and allows the operator to override the system that has experienced a cutout situation.



13. Soft Touch/SkyGuard Indicator (If Equipped)

Indicates the Soft Touch bumper is against an object or the SkyGuard sensor has been activated. All controls are cut out until the override button is pushed. For Soft Touch, controls are then active in the Creep Mode or for SkyGuard, controls will work normally.

14. Tower Boom Lift

Provides for raising and lowering of the tower boom when positioned up or down.



15. Platform Rotate

Provides rotation of the platform when positioned to the right or left.



16. Function Speed Control

This control affects the speed of telescope, tower lift and jib lift. Turning the knob all the way counterclockwise until it clicks puts drive, tower lift and swing into creep mode. This slow speed is used for fine positioning of the platform when close to obstacles.



NOTE: *Main lift and swing functions may be selected at the same time. Maximum speed is reduced when both functions are selected.*

NOTE: *To operate the Main Lift/Swing controller, pull up on the locking ring below the handle.*

17. Main Lift/Swing Controller

Provides main lift and swing. Push forward to lift up, pull backward to boom down. Move right to swing right, move left to swing left. Moving the joystick activates switches to provide the functions selected.

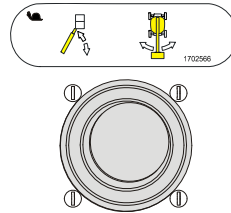

Platform Control Indicator Panel

1. AC Generator (Green) (If equipped)
2. Platform Overload Indicator. (If equipped)

Indicates the generator is in operation.

Indicates the platform has been overloaded.



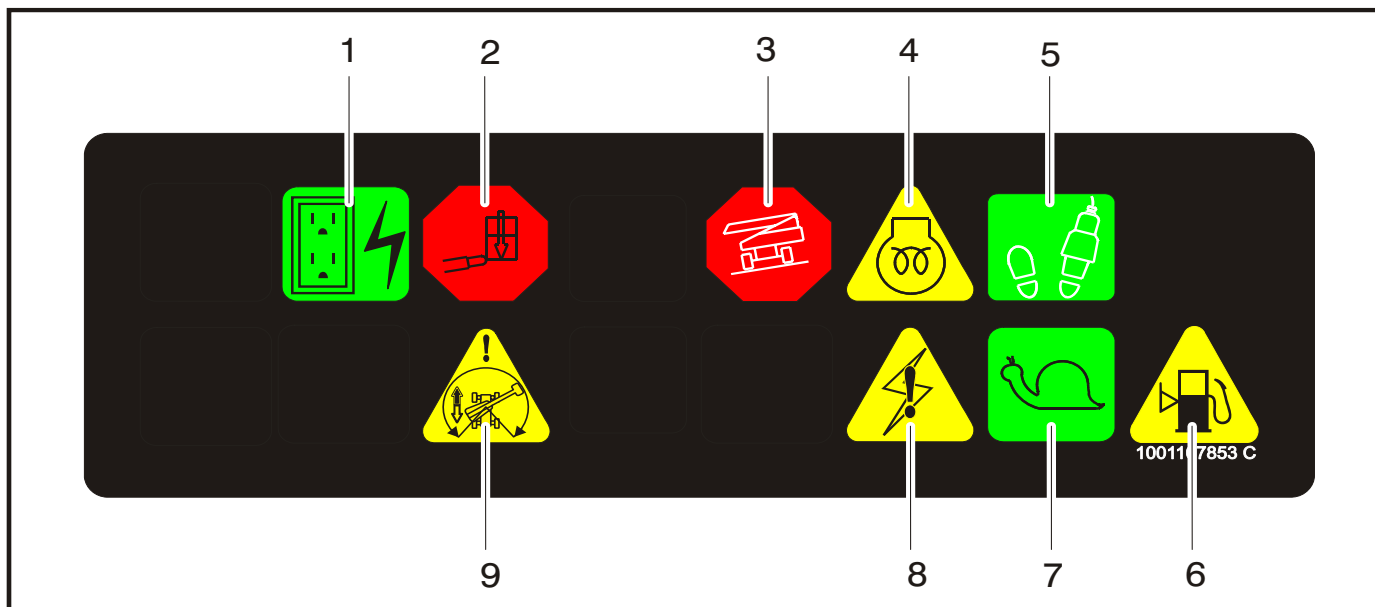

- | | | |
|-----------------------|----------------------------|----------------------|
| 1. AC Generator | 4. Glow Plug/Wait to Start | 7. Creep Speed |
| 2. Platform Overload | 5. Enable/Footswitch | 8. System Distress |
| 3. Tilt Alarm Warning | 6. Fuel Level | 9. Drive Orientation |

Figure 3-6. Platform Control Indicator Panel

3. Tilt Alarm Warning Light and Alarm

| Tilt Angle | Market |
|------------|-------------------|
| 3° | CE & Australia |
| 5° | ANSI, CSA & Japan |

This illuminator indicates that the chassis is on a slope. An alarm will also sound when the chassis is on a severe slope and the boom is above horizontal. If lit when boom is raised or extended, retract and lower to below horizontal then reposition machine so that it is level before continuing operation. If the boom is above horizontal and the machine is on a severe slope, the tilt alarm warning light will illuminate and an alarm will sound and CREEP is automatically activated.



WARNING

IF TILT WARNING LIGHT IS ILLUMINATED WHEN BOOM IS RAISED OR EXTENDED, RETRACT AND LOWER TO BELOW HORIZONTAL THEN REPOSITION MACHINE SO THAT IT IS LEVEL BEFORE EXTENDING BOOM OR RAISING BOOM ABOVE HORIZONTAL.

4. Glow Plug/Wait to Start Indicator

Indicates the glow plugs are operating. After turning on ignition, wait until light goes out before starting engine.



SECTION 3 - MACHINE CONTROLS AND INDICATORS

5. Enable Indicator/Footswitch



To operate any function, the footswitch must be depressed and the function selected within seven seconds. The enable indicator shows that the controls are enabled. If a function is not selected within seven seconds, or if a seven second lapse between ending one function and beginning the next function, the enable light will go out and the footswitch must be released and depressed again to enable the controls.

Releasing the footswitch removes power from all controls and applies the drive brakes.

NOTE: For engine starting, the footswitch must be in the released (up) position.

WARNING

TO AVOID SERIOUS INJURY, DO NOT REMOVE, MODIFY OR DISABLE THE FOOTSWITCH BY BLOCKING OR ANY OTHER MEANS.

WARNING

FOOTSWITCH MUST BE ADJUSTED IF FUNCTIONS ACTIVATE WHEN SWITCH ONLY OPERATES WITHIN LAST 1/4" OF TRAVEL, TOP OR BOTTOM.

6. Low Fuel Indicator (Yellow)

Indicates fuel tank is 1/8 full or less.



NOTE: Refer to Fuel Reserve/Shut-Off System in Section 4 for detailed information.

7. Creep Speed Indicator

When the Function Speed Control is turned to the creep position, the indicator acts as a reminder that all functions are set to the slowest speed. The light flashes if the control system puts the machine into creep speed and will be on continuously if the operator selects creep speed.



8. System Distress Indicator

The light indicates that the JLG Control System has detected an abnormal condition and a Diagnostic Trouble Code has been set in the system memory. Refer to the Service Manual for instructions concerning the trouble codes and trouble code retrieval



9. Drive Orientation Indicator

When the boom is swung beyond the rear drive tires or further in either direction, the Drive Orientation indicator will illuminate when the drive function is selected. This is a signal for the operator to verify that the drive control is being operated in the proper direction (i.e. controls reversed situations).



SECTION 4. MACHINE OPERATION

4.1 DESCRIPTION

This machine is a self-propelled hydraulic lift equipped with a work platform on the end of an elevating, articulating and rotating boom.

The primary operator control station is in the platform. From this control station, the operator can drive and steer the machine in both forward and reverse directions. The operator can raise or lower the boom or swing the boom to the left or right. Standard boom swing is 360 degree non continuous left and right of the stowed position. The machine has a Ground Control Station which will override the Platform Control Station. Ground Controls operate Boom Lift and Swing, and are to be used in an emergency to lower the platform to the ground should the operator in the platform be unable to do so. The Ground Control is also to be used in Pre-Start Inspection.

4.2 OPERATING CHARACTERISTICS AND LIMITATIONS

Capacities

Raising boom above horizontal with or without any load in platform is based on the following criteria:

1. Machine is positioned on a smooth, firm and level surface.
2. Load is within manufacturer's rated capacity.
3. All machine systems are functioning properly.
4. Proper tire pressure.
5. Machine is as originally equipped from JLG.

Stability

Machine stability is based on two (2) conditions which are called FORWARD and BACKWARD stability. The machine's position of least FORWARD stability is shown in (See Figure 4-1.), and its position of least BACKWARD stability is shown in (See Figure 4-2.)

WARNING

TO AVOID FORWARD OR BACKWARD TIPPING, DO NOT OVERLOAD MACHINE OR OPERATE THE MACHINE ON AN OUT-OF-LEVEL SURFACE.

4.3 ENGINE OPERATION

NOTE: *Initial starting must always be performed from the Ground Control station.*

Starting Procedure

CAUTION

IF ENGINE FAILS TO START PROMPTLY, DO NOT CRANK FOR AN EXTENDED TIME. SHOULD ENGINE FAIL TO START AGAIN, ALLOW STARTER TO "COOL OFF" FOR 2-3 MINUTES. IF ENGINE FAILS AFTER SEVERAL ATTEMPTS, REFER TO ENGINE MAINTENANCE MANUAL.

NOTE: *Diesel engines only: After turning on ignition, operator must wait until glow plug indicator light goes out before cranking engine.*

1. Turn key of SELECT switch to GROUND. Position POWER/ EMERGENCY STOP switch to ON, then push the ENGINE START switch until engine starts.

CAUTION

ALLOW ENGINE TO WARM-UP FOR A FEW MINUTES AT LOW SPEED BEFORE APPLYING ANY LOAD.

2. After engine has had sufficient time to warm up, shut engine off.
3. Turn SELECT switch to PLATFORM.
4. From Platform, pull POWER/EMERGENCY STOP switch out, then push the ENGINE START switch until engine starts.

NOTE: *Footswitch must be in released (up) position before starter will operate. If starter operates with footswitch in the depressed position, DO NOT OPERATE MACHINE.*

Shutdown Procedure



IF AN ENGINE MALFUNCTION CAUSES AN UNSCHEDULED SHUTDOWN, DETERMINE THE CAUSE AND CORRECT IT BEFORE RESTARTING THE ENGINE.

1. Remove all load and allow engine to operate at low speed for 3-5 minutes; this allows further reduction of internal engine temperature.
2. Push POWER/EMERGENCY STOP switch in.
3. Turn Platform/Ground Select switch to Off.

Refer to Engine Manufacturer's manual for detailed information.

Fuel Reserve / Shut-Off System

NOTE: Reference the Service and Maintenance Manual along with a qualified JLG Mechanic to verify your machine setup.

The Fuel Shutoff System monitors the fuel in the tank and senses when the fuel level is getting low. The JLG Control System automatically shuts the engine down before the fuel tank is emptied unless the machine is set up for Engine Restart.



If fuel level reaches the Empty range, the Low Fuel light will begin to flash once a second and there will be approximately 60 minutes of engine run time left. If the system is in this condition and automatically shuts down the engine or if the operator manually shuts down the engine before the 60 minute run time is complete, the Low Fuel light will flash 10 times a second and the engine will react according to machine setup. Setup options are as follows:

- Engine One Restart - When the engine shuts down, the operator will be permitted to cycle power and restart the engine once with approximately 2 minutes of run time. After the 2 minute run time is complete or if the engine is shut down by the operator prior to the completion of the 2 minute run time, it cannot be restarted until fuel is added to the tank.
- Engine Restart - When the engine shuts down, the operator will be permitted to cycle power and restart the engine for approximately 2 minutes of run time. After the 2 minutes of run time is complete, the operator may cycle power and restart the engine for an additional 2 minutes of run time. The operator can repeat this process until there is no more fuel available.
- Engine Stop - When the engine shuts down, no restarts will be permitted until fuel is added to the tank.

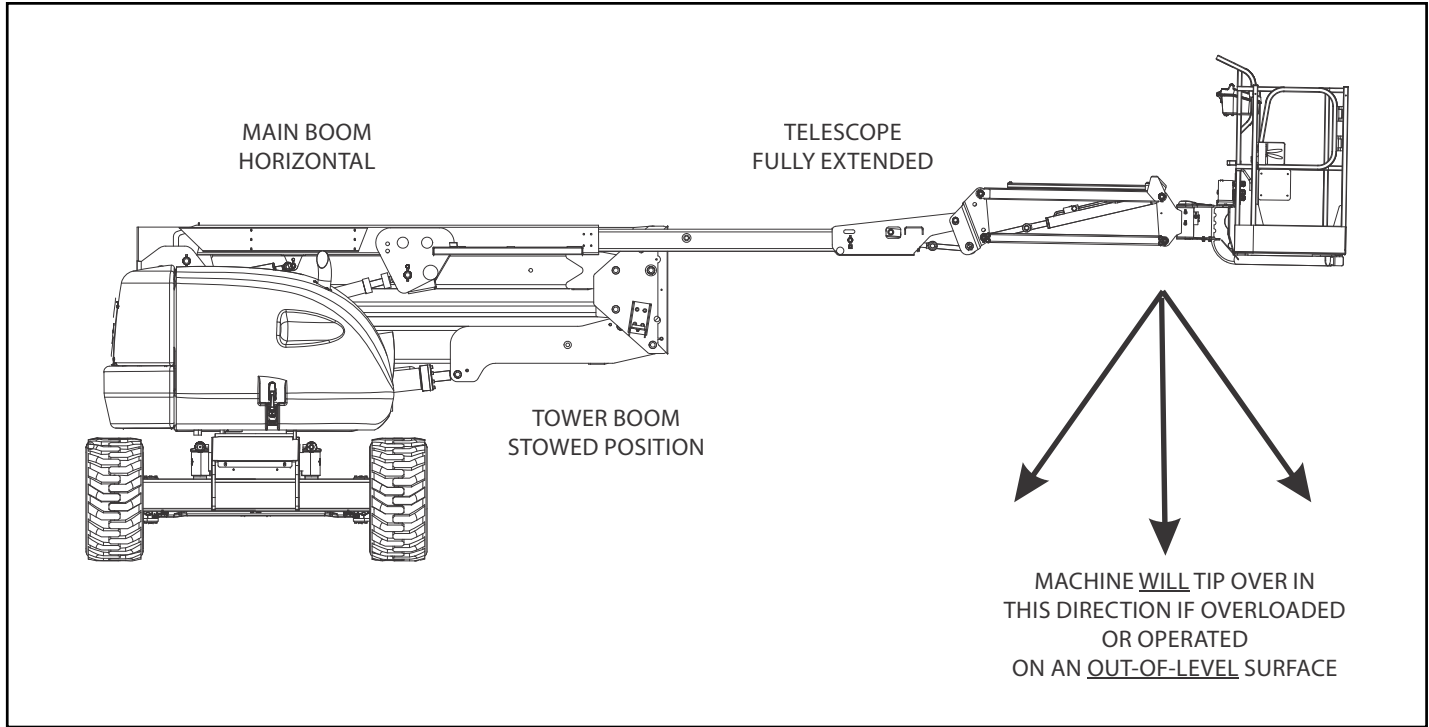

Figure 4-1. Position of Least Forward Stability

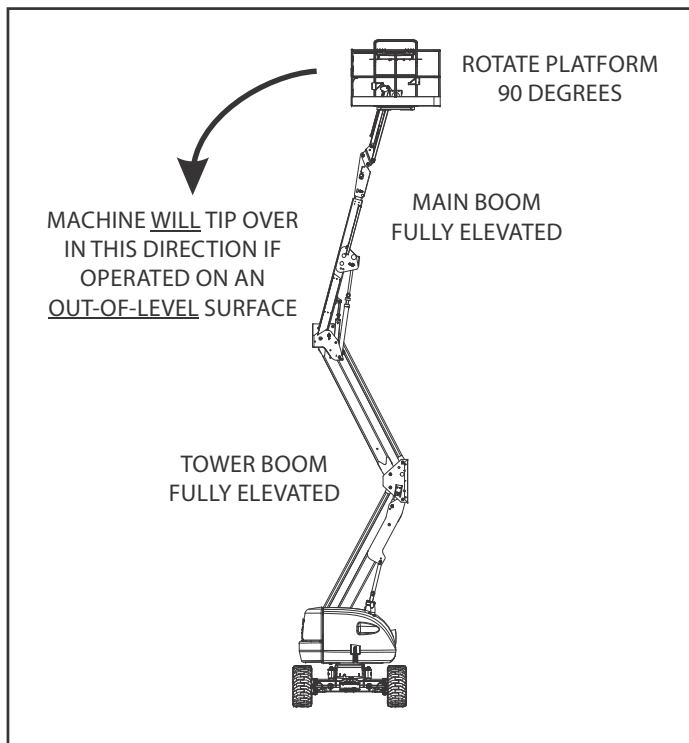
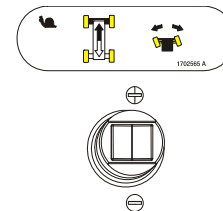
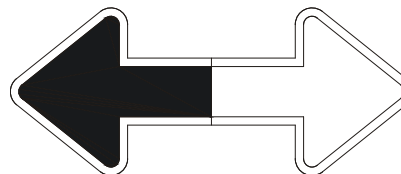

Figure 4-2. Position of Least Backward Stability

4.4 TRAVELING (DRIVING)

NOTE: Refer to the Operating Specifications table in Section 6 for Gradeability and Sideslope ratings.

All ratings for Gradeability and Sideslope are based upon the machine's boom being in the stowed position, fully lowered, and retracted.



Traveling is limited by two factors:

1. Gradeability, which is the percent of grade of the incline the machine can climb.
2. Sideslope, which is the angle of the slope the machine can be driven across.

 WARNING

DO NOT DRIVE WITH BOOM ABOVE HORIZONTAL EXCEPT ON A SMOOTH, FIRM AND LEVEL SURFACE.

TO AVOID LOSS OF TRAVEL CONTROL OR “TIP OVER”, DO NOT DRIVE MACHINE ON GRADES EXCEEDING THOSE SPECIFIED ON THE SERIAL NUMBER TAG OR AS NOTED IN THE OPERATORS MANUAL.

DO NOT DRIVE ON SIDESLOPES WHICH EXCEED 5 DEGREES (ANSI MARKETS) OR 4 DEGREES (CE & AUSTRALIA MARKETS).

USE EXTREME CAUTION WHEN DRIVING IN REVERSE AND AT ALL TIMES WHEN THE PLATFORM IS ELEVATED ESPECIALLY WHEN DRIVING WITH ANY PART OF MACHINE WITHIN 6 FEET (2 M) OF AN OBSTRUCTION.

TRAVEL GRADES WITH DRIVE SPEED/TORQUE SELECT SWITCH IN THE FORWARD POSITION.

BEFORE DRIVING, LOCATE THE BLACK/WHITE ORIENTATION ARROWS ON BOTH THE CHASSIS AND THE PLATFORM CONTROLS. MOVE THE DRIVE CONTROLS IN A DIRECTION MATCHING THE DIRECTIONAL ARROWS.

Traveling Forward and Reverse

1. With the engine running, activate footswitch.
2. Position Drive controller to FORWARD or REVERSE as desired.

This machine is equipped with a Drive Orientation Indicator. The yellow light on the platform control console indicates that the boom is swung beyond the rear drive tires and the machine may Drive/Steer in the opposite direction from the movement of the controls. If the indicator is illuminated, operate the Drive function in the following manner:

1. Match the black and white direction arrows on both platform control panel and the chassis to determine the direction the machine will travel.
2. Push and release the Drive Orientation Override switch. Within 3 seconds, slowly move the Drive control toward the arrow matching the intended direction of machine travel. The indicator light will flash during the 3 second interval until the drive function is selected.

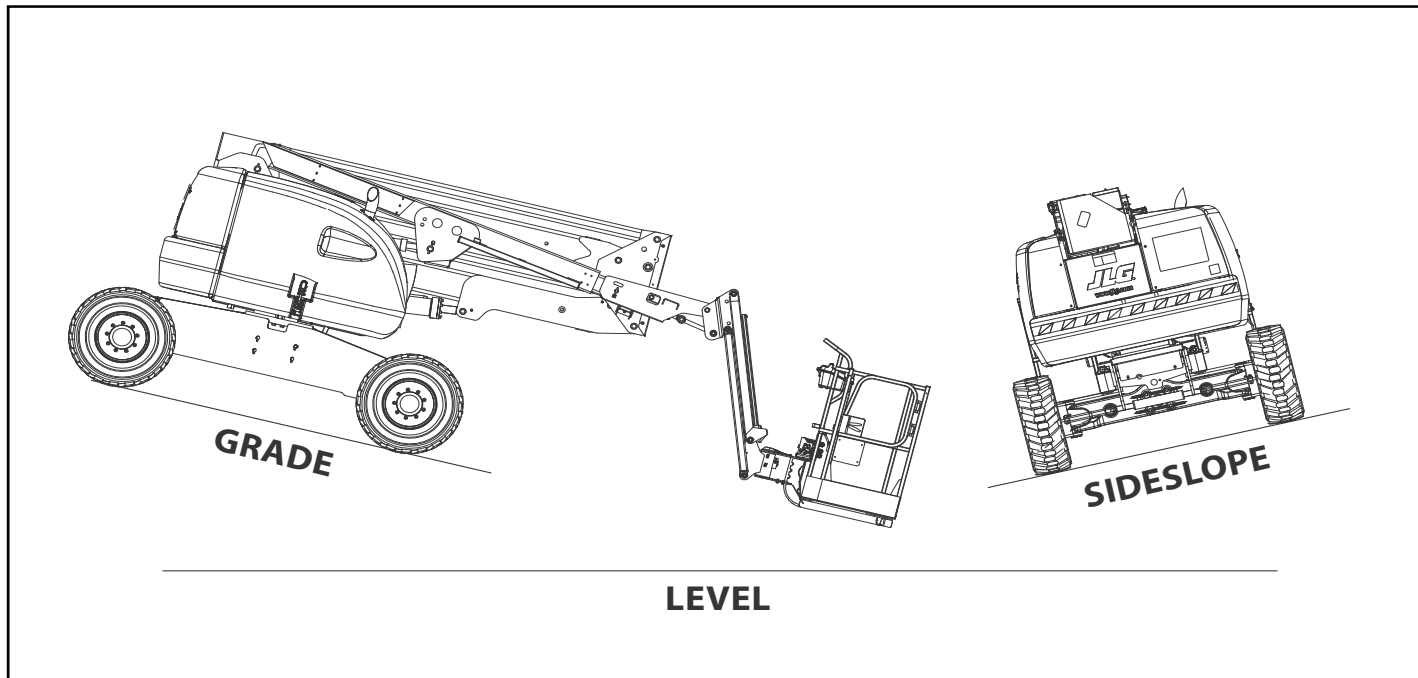

Figure 4-3. Grade and Side Slopes

4.5 STEERING

Position thumb switch on Drive/Steer controller to RIGHT for steering right, or to LEFT for steering left.

4.6 PLATFORM

WARNING

ONLY USE THE PLATFORM LEVELING OVERRIDE FUNCTION FOR SLIGHT LEVELING OF THE PLATFORM. INCORRECT USE COULD CAUSE THE LOAD/OCCUPANTS TO SHIFT OR FALL. FAILURE TO DO SO COULD RESULT IN DEATH OR SERIOUS INJURY.

Platform Level Adjustment

This switch is used to adjust the platform level in situations such as ascending/descending a grade. To Level Up or Down - Position the Platform/Level control switch Up or Down and hold until the platform is level.

Platform Rotation

To rotate the platform to the left or right, use the Platform Rotate control switch to select the direction and hold until desired position is reached.

4.7 BOOM

WARNING

A RED TILT WARNING LIGHT IS LOCATED ON THE CONTROL CONSOLE WHICH LIGHTS WHEN THE CHASSIS IS ON AN EXCESSIVE SLOPE. DO NOT SWING OR RAISE BOOM ABOVE HORIZONTAL WHEN LIGHT IS LIT.

DO NOT DEPEND ON TILT ALARM AS A LEVEL INDICATOR FOR THE CHASSIS. TILT ALARM INDICATES CHASSIS IS ON AN EXCESSIVE SLOPE (3 DEGREE OR GREATER ON CE & AUSTRALIA SPEC MACHINES, 5 DEGREE OR GREATER ON ANSI, CSA, & JAPAN SPEC MACHINES). CHASSIS MUST BE LEVEL BEFORE SWINGING, OR RAISING BOOM ABOVE HORIZONTAL OR DRIVING WITH THE BOOM ELEVATED.

TO AVOID TIP OVER IF RED TILT WARNING LIGHT LIGHTS WHEN BOOM IS RAISED ABOVE HORIZONTAL, LOWER PLATFORM TO GROUND LEVEL. THEN REPOSITION MACHINE SO THAT CHASSIS IS LEVEL BEFORE RAISING BOOM.

TRAVELING WITH BOOM BELOW HORIZONTAL IS PERMITTED ON GRADES AND SIDE SLOPES SPECIFIED IN THE OPERATING SPECIFICATIONS SECTION OF THIS MANUAL.

WARNING

TO AVOID SERIOUS INJURY, DO NOT OPERATE MACHINERY IF ANY CONTROL LEVER OR TOGGLE SWITCH CONTROLLING PLATFORM MOVEMENT DOES NOT RETURN TO THE 'OFF' OR NEUTRAL POSITION WHEN RELEASED.

CAUTION

TO AVOID A COLLISION AND INJURY IF PLATFORM DOES NOT STOP WHEN A CONTROL SWITCH OR LEVER IS RELEASED, REMOVE FOOT FROM FOOTSWITCH OR USE EMERGENCY STOP SWITCH TO STOP THE MACHINE.

Swinging the Boom

To swing boom, use Main Lift/Swing controller to select RIGHT or LEFT direction.

Raising and Lowering the Tower Boom

To raise or lower the Tower Boom, use Tower Boom Lift switch to select UP or DOWN movement.

Raising and Lowering the Main Boom

To raise or lower the Main Boom, use Main Boom Lift switch to select UP or DOWN movement.

Telescoping the Main Boom

To extend or retract the main boom, use the Main Telescope Control Switch to select IN or OUT movement.

4.8 FUNCTION SPEED CONTROL

This control affects the speed of all boom functions to the right of the control and, also, Platform Level. When in the Counterclockwise maximum position, Drive and all boom functions are placed in creep speed.

4.9 MACHINE SAFETY SYSTEM OVERRIDE (MSSO)(CE ONLY)

The Machine Safety System Override (MSSO) is used to override function controls for Emergency Platform Retrieval only. Refer to Section 5.5, Machine Safety System Override (MSSO)(CE Only) for operating procedures.



4.10 SKYGUARD OPERATION

Skyguard is used to provide enhanced control panel protection. When the SkyGuard sensor is activated, functions that were in use at the time of actuation will reverse or cutout. The table below outlines these functions.

Table 4-1. Skyguard Function Table

| Main Lift | Main Tele | Swing | Drive Forward | | Drive Reverse | | Platform Level | Platform Rotate | Jib Lift |
|--|-----------|-------|---------------|---|---------------|---|----------------|-----------------|----------|
| R | C/R* | R | R | I | R | R | C | C | C |
| R = Indicates Reversal is Activated | | | | | | | | | |
| C = Indicates Cutout is Activated | | | | | | | | | |
| I = Input is Ignored | | | | | | | | | |
| Note: When Soft Touch is enabled with SkyGuard all functions are cut out only. | | | | | | | | | |
| * Reversal only applies to Main Tele Out. Main Tele In would be cut out | | | | | | | | | |

4.11 AUXILIARY PUMP

NOTICE

WHEN OPERATING ON AUXILIARY POWER, DO NOT OPERATE MORE THAN ONE FUNCTION AT THE SAME TIME. SIMULTANEOUS OPERATION CAN OVERLOAD THE AUXILIARY PUMP MOTOR.

The main function of auxiliary power is to lower the platform in the event of primary power failure. Determine the reason for primary power failure and have the problem corrected by a certified JLG service technician. Operate as follows:

1. Position Platform/Ground switch to Platform.
2. Position Power/Emergency Stop switch to the on position.
3. Depress and hold footswitch.
4. Position Auxiliary Power switch to the on position and hold.
5. Operate appropriate control switch or lever for desired function and hold.
6. Release Auxiliary Power switch, selected control switch or lever, and footswitch.
7. Position Power/Emergency Stop switch to the off position.

4.12 OSCILLATING AXLE LOCKOUT TEST (IF EQUIPPED)

NOTICE

LOCKOUT SYSTEM TEST MUST BE PERFORMED QUARTERLY, ANY TIME A SYSTEM COMPONENT IS REPLACED, OR WHEN IMPROPER SYSTEM OPERATION IS SUSPECTED.

Refer to Section 2.3, Oscillating Axle Lockout Test (If Equipped) for procedure.

4.13 SHUT DOWN AND PARK

The procedures to shut down and park the machine are as follows:

1. Drive machine to a reasonably well protected area.
2. Ensure boom is lowered over rear drive axle.
3. Shut down Emergency Stop at Platform Controls.
4. Shut down Emergency Stop at Ground Controls. Position Platform/Ground Select switch to center OFF.
5. If necessary, cover Platform Controls to protect instruction placards, warning decals, and operating controls from hostile environment.

4.14 LIFTING AND TIE DOWN

Lifting

1. Refer to the Serial Number Tag, call JLG Industries, or weigh the individual unit to find out the Gross Vehicle Weight.
2. Place the boom in the stowed position.
3. Remove all loose items from the machine.
4. Properly adjust the rigging to prevent damage to the machine and so the machine remains level.

Tie Down

NOTICE

WHEN TRANSPORTING THE MACHINE, THE BOOM MUST BE FULLY LOWERED INTO THE BOOM REST.

1. Place the boom in the stowed position.
2. Remove all loose items from the machine.
3. Secure the chassis and the platform using straps or chains of adequate strength.

SECTION 4 - MACHINE OPERATION

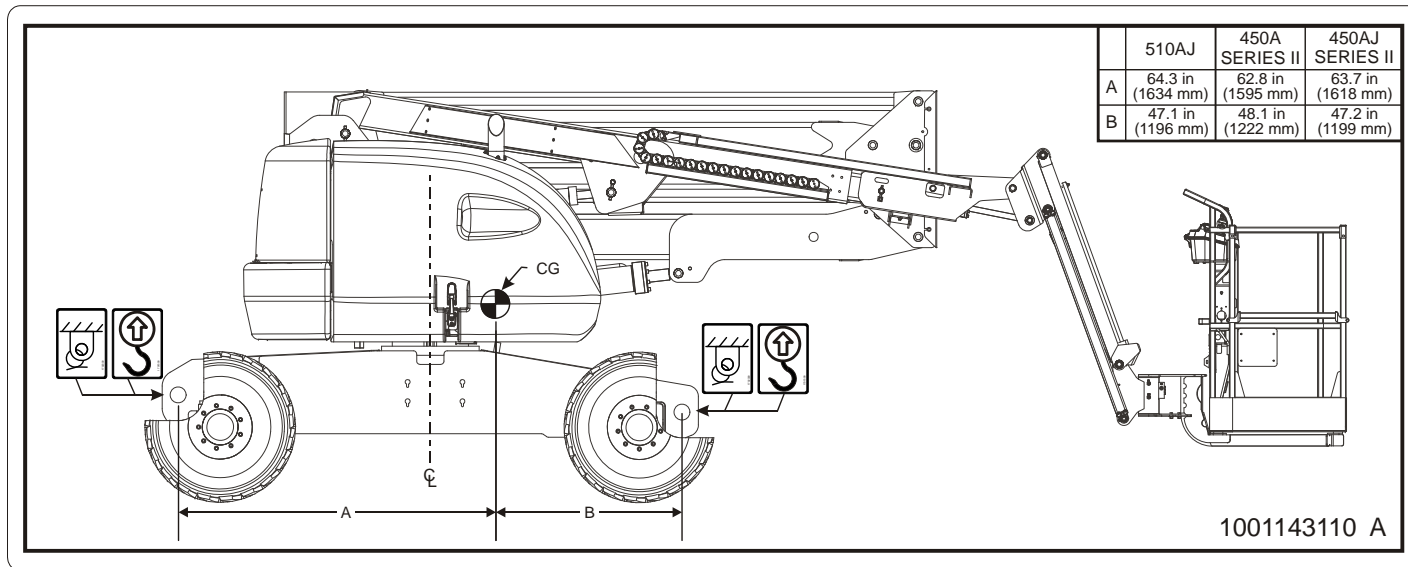

Figure 4-4. Lifting and Tie Down Chart

4.15 TOWING

⚠ WARNING

RUNAWAY VEHICLE/MACHINE HAZARD. MACHINE HAS NO TOWING BRAKES. TOWING VEHICLE MUST BE ABLE TO CONTROL MACHINE AT ALL TIMES. ON-HIGHWAY TOWING NOT PERMITTED. FAILURE TO FOLLOW INSTRUCTIONS COULD CAUSE SERIOUS INJURY OR DEATH.

MAXIMUM TOWING SPEED 5 M.P.H. (8 K.M.H.) FOR NO LONGER THAN 30-45 MINUTES.

MAXIMUM TOWING GRADE 25%.

Prior to Towing

Prior to towing the machine, complete the following:

⚠ CAUTION

DO NOT TOW MACHINE WITH ENGINE OPERATING OR DRIVE HUBS ENGAGED.

1. Retract, lower and position boom over rear drive wheels in line with direction of travel.
2. Disconnect drive hubs by inverting disconnect cap. (See Figure 4-5.) After towing the machine, complete the following:

3. Reconnect drive hubs by inverting disconnect cap. (See Figure 4-5.)

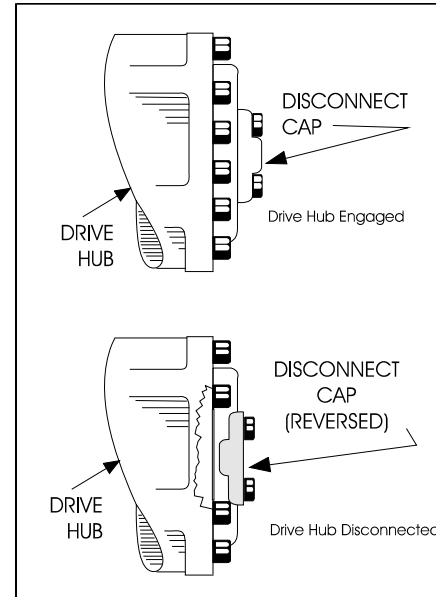

Figure 4-5. Drive Disconnect Hub

4.16 DUAL FUEL SYSTEM (GAS ENGINE ONLY)

The dual fuel system enables the standard gasoline engine to run on either gasoline or LP gas.



IT IS POSSIBLE TO SWITCH FROM ONE FUEL SOURCE TO THE OTHER WITHOUT ALLOWING THE ENGINE TO STOP. EXTREME CARE MUST BE TAKEN AND THE FOLLOWING INSTRUCTIONS MUST BE FOLLOWED.

Changing From Gasoline to LP Gas

1. Start engine from Ground Control Station.
2. Open hand valve on LP gas supply tank by turning counter-clockwise.
3. While engine is operating on GASOLINE under a no-load condition, place FUEL SELECT switch at Platform Control to LP position.

Changing From LP Gas to Gasoline

1. With engine operating on LP under a no-load condition, position FUEL SELECT switch at Platform Control Station to GASOLINE position.
2. Close hand valve on LP gas supply tank by turning clockwise.

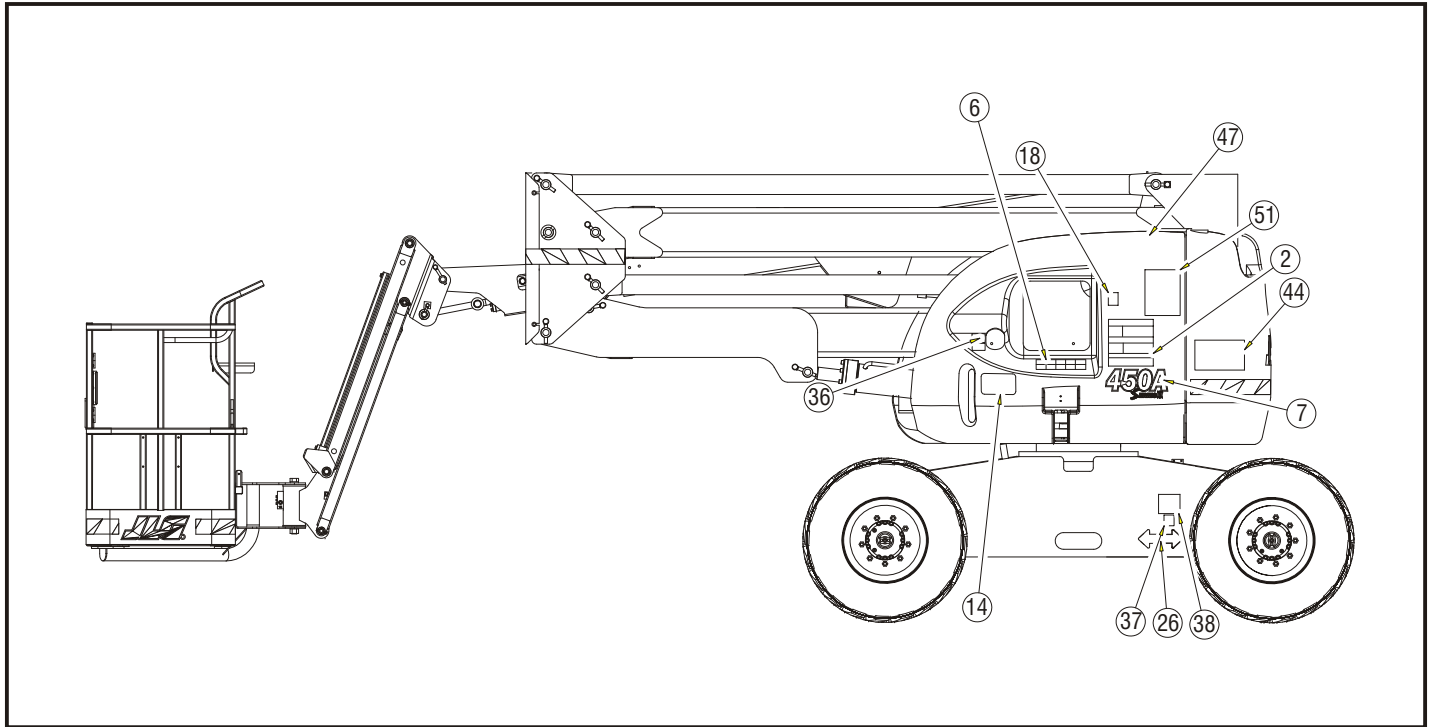

Figure 4-6. Decal Installation - Sheet 1 of 6

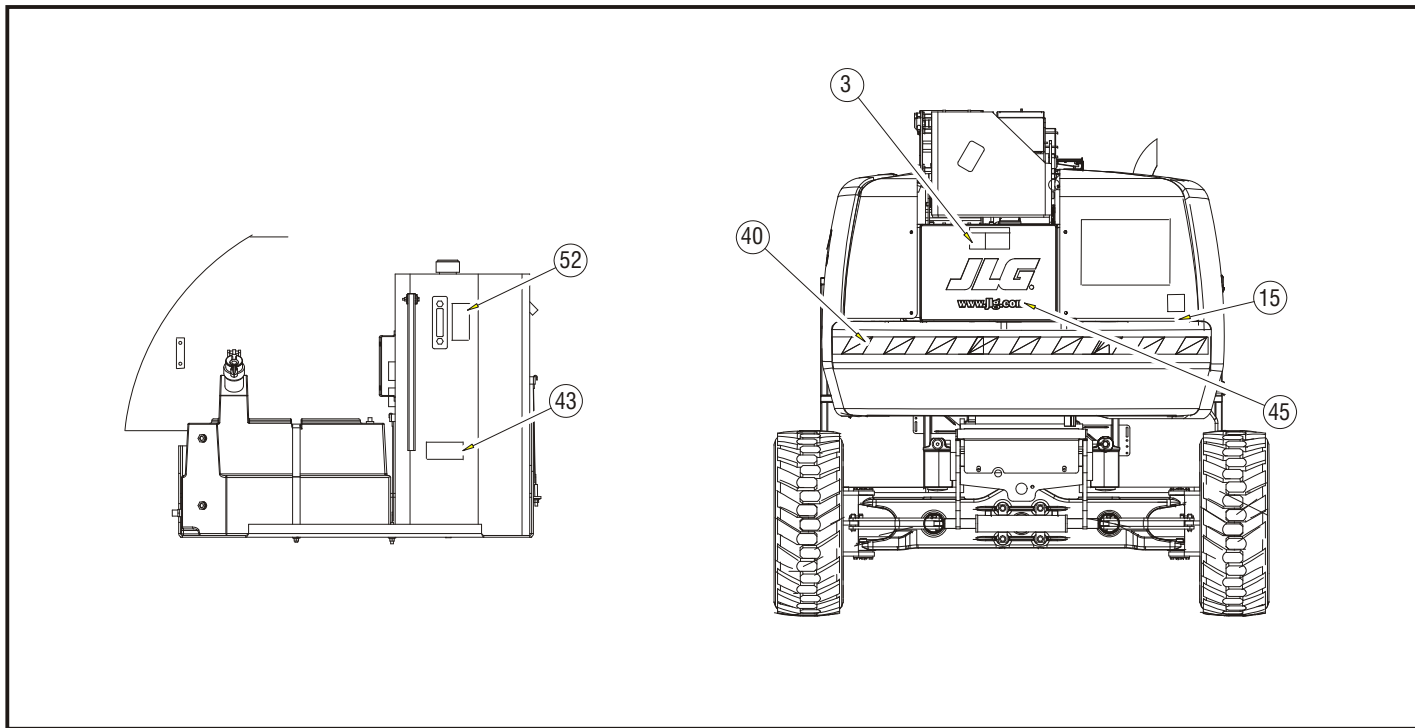

Figure 4-7. Decal Installation - Sheet 2 of 6

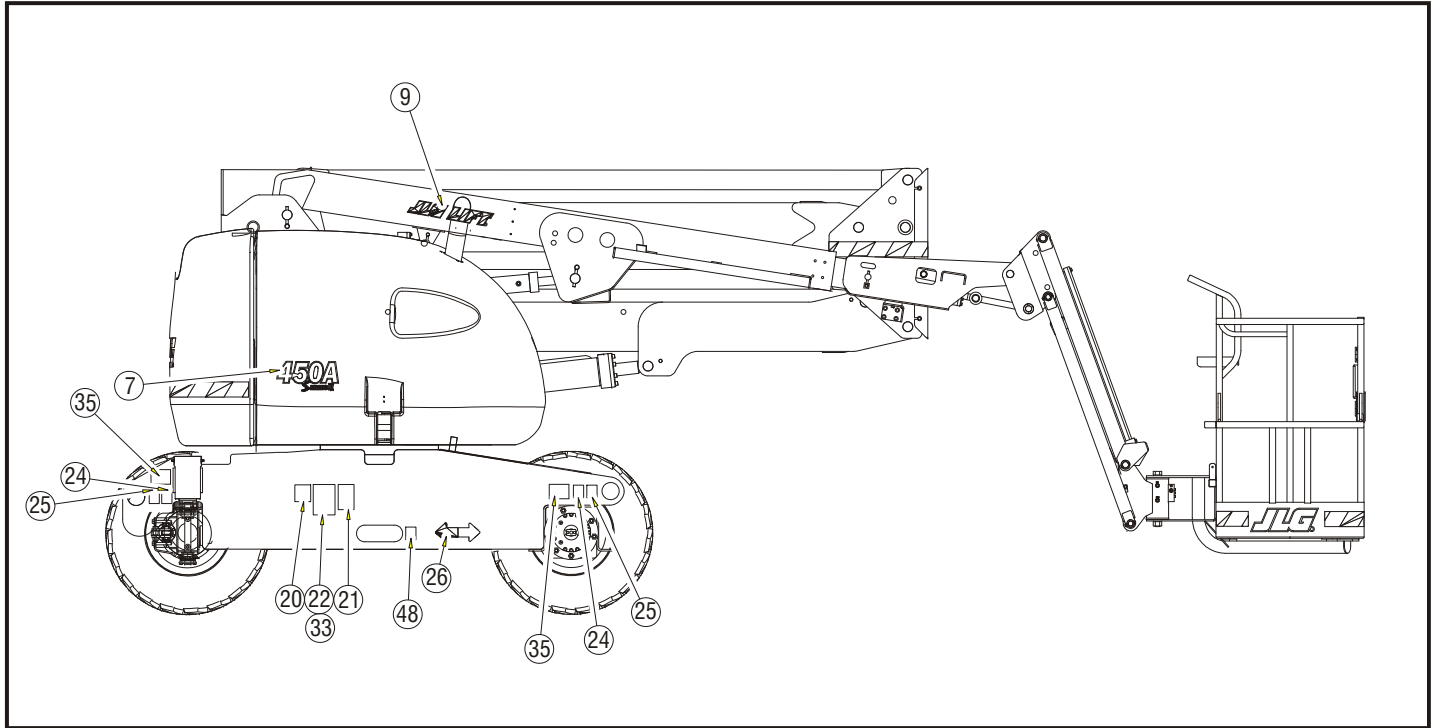

Figure 4-8. Decal Installation - Sheet 3 of 6

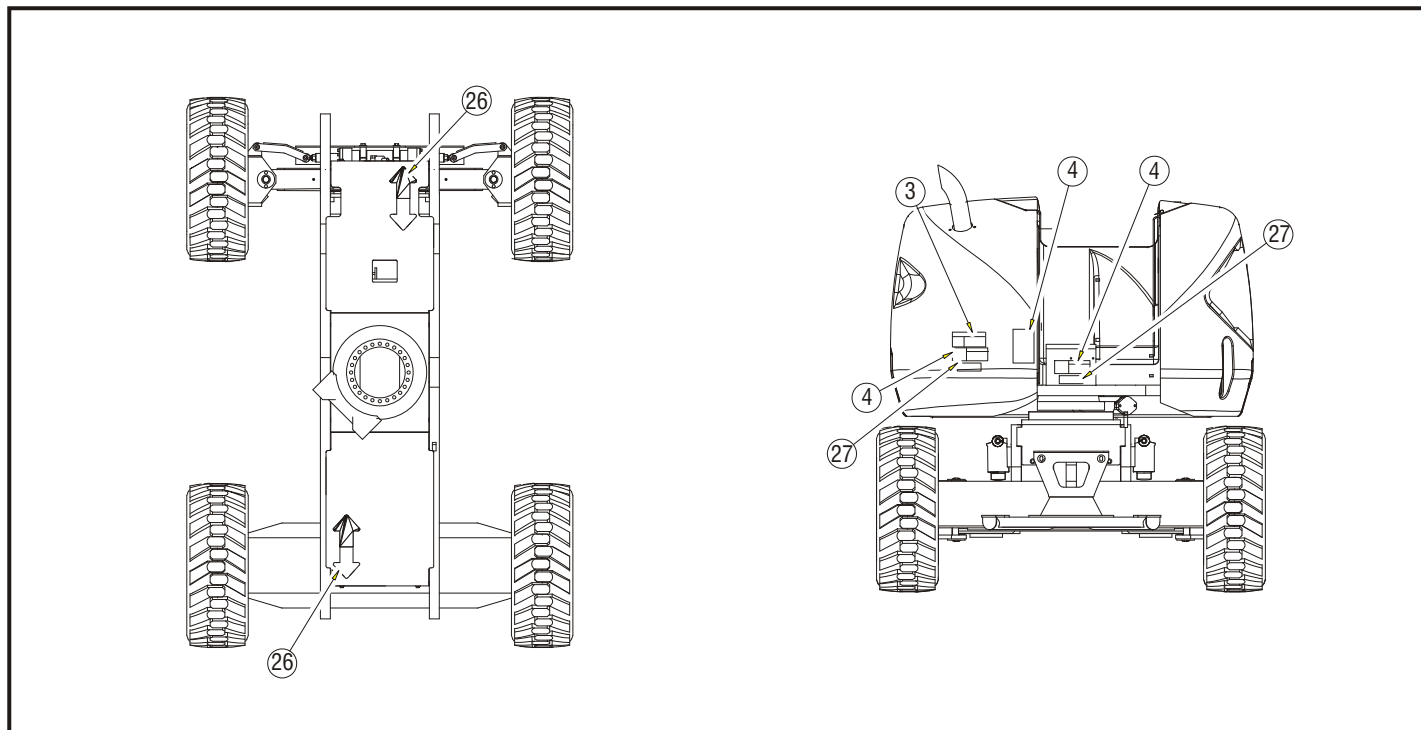

Figure 4-9. Decal Installation - Sheet 4 of 6

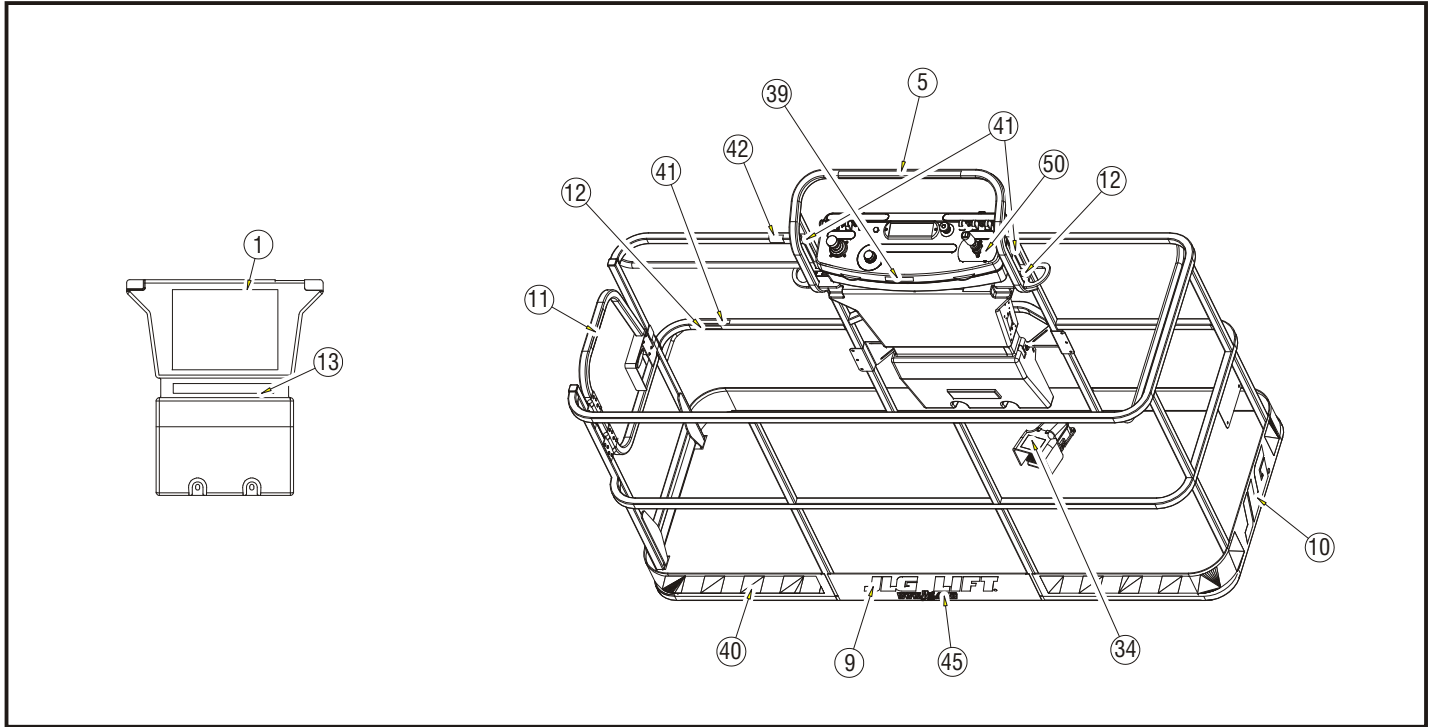

Figure 4-10. Decal Installation - Sheet 5 of 6

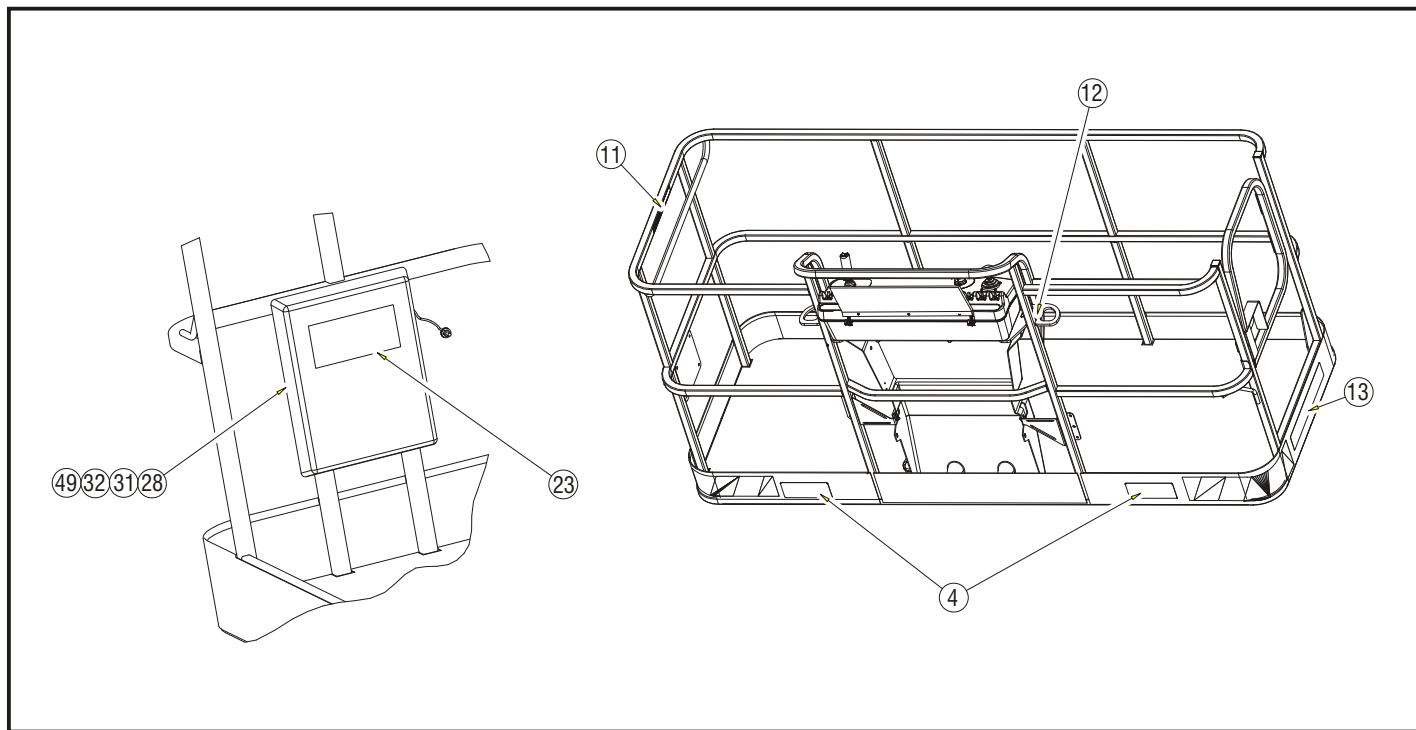

Figure 4-11. Decal Installation - Sheet 6 of 6

Table 4-2. Decal Legend

| Item # | ANSI 1001143099-D | Australian 1001143100-D | Japanese 1001143101-D | Korean 1001143102-D | French 1001143103-D | Chinese 1001143104-D | Portuguese/ Spanish 1001143105-D | CE 1001143106-D | English/ Spanish 1001143107-D |
|---------------|------------------------------|------------------------------------|----------------------------------|--------------------------------|--------------------------------|---------------------------------|---|----------------------------|--|
| 1 | 1703797 | 1703992 | 1703926 | 1703927 | 1703924 | 1703925 | 1703928 | 1705821 | 1703923 |
| 2 | 1703798 | 1705332 | 1703932 | 1703933 | 1703930 | 1703931 | 1703934 | 1705822 | 1703929 |
| 3 | 1703805 | -- | 1703938 | 1703939 | 1703936 | 1703937 | 1703940 | -- | 1703935 |
| 4 | 1703804 | 1701518 | 1703950 | 1703951 | 1703948 | 1703949 | 1703952 | 1701518 | 1703947 |
| 5 | 1001108493 | -- | -- | -- | 1001108493 | -- | -- | -- | 1001108493 |
| 6 | 1706941 | -- | -- | -- | 1706941 | -- | -- | -- | 1706941 |
| 7 | -- | -- | -- | -- | -- | -- | -- | -- | -- |
| 8 | -- | -- | -- | -- | -- | -- | -- | -- | -- |
| 9 | -- | -- | -- | -- | -- | -- | -- | -- | -- |
| 10 | -- | -- | -- | -- | -- | -- | -- | -- | -- |
| 11 | 1702868 | -- | -- | -- | 1704000 | -- | 1704002 | -- | 1704001 |
| 12 | 1704277 | 1704277 | 1704277 | 1704277 | 1704277 | 1704277 | 1704277 | 1704277 | 1704277 |
| 13 | 1001121801 | -- | 1001121808 | 1001121918 | 1001121803 | 1001121810 | 1001121920 | -- | 1001121805 |
| 14 | 1001121814 | -- | 1001121821 | 1001121821 | 1001121816 | 1001121823 | 1001121923 | -- | 1001121818 |
| 15 | -- | -- | -- | -- | -- | -- | -- | 1705084 | -- |
| 16 | -- | -- | -- | -- | -- | -- | -- | -- | -- |
| 17 | -- | -- | -- | -- | -- | -- | -- | -- | -- |

SECTION 4 - MACHINE OPERATION

Table 4-2. Decal Legend

| Item # | ANSI 1001143099-D | Australian 1001143100-D | Japanese 1001143101-D | Korean 1001143102-D | French 1001143103-D | Chinese 1001143104-D | Portuguese/ Spanish 1001143105-D | CE 1001143106-D | English/ Spanish 1001143107-D |
|--------|----------------------|----------------------------|--------------------------|------------------------|------------------------|-------------------------|--|--------------------|-------------------------------------|
| 18 | 1701504 | 1701504 | 1701504 | 1701504 | 1701504 | 1701504 | 1701504 | 1701504 | 1701504 |
| 19 | -- | -- | -- | -- | 1704006 | -- | 1704008 | -- | 1704007 |
| 20 | 1702631 | 1702631 | 1702631 | 1702631 | 1702631 | 1702631 | 1702631 | 1702631 | 1702631 |
| 21 | 1001131269 | -- | -- | -- | 1001131269 | -- | -- | -- | -- |
| 22 | -- | 1702958 | -- | -- | -- | -- | -- | -- | -- |
| 23 | 1701509 | 1701509 | 1701509 | 1701509 | 1701509 | 1701509 | 1701509 | 1701509 | 1701509 |
| 24 | 1702300 | 1702300 | 1702300 | 1702300 | 1702300 | 1702300 | 1702300 | 1702300 | 1702300 |
| 25 | 1701500 | 1701500 | 1701500 | 1701500 | 1701500 | 1701500 | 1701500 | 1701500 | 1701500 |
| 26 | 1701529 | 1701529 | 1701529 | 1701529 | 1701529 | 1701529 | 1701529 | 1701529 | 1701529 |
| 27 | 3251243 | 3251242 | -- | -- | 3251243 | -- | 3251243 | -- | 3251243 |
| 28 | -- | -- | -- | -- | -- | -- | -- | -- | -- |
| 29 | -- | -- | -- | -- | -- | -- | -- | -- | -- |
| 30 | -- | -- | -- | -- | -- | -- | -- | -- | -- |
| 31 | -- | -- | -- | -- | -- | -- | -- | -- | -- |
| 32 | -- | -- | -- | -- | -- | -- | -- | -- | -- |
| 33 | -- | -- | -- | -- | -- | -- | -- | -- | -- |
| 34 | 3252347 | 3252347 | 1703980 | 1703981 | 1703984 | 1703982 | 1703985 | 1705828 | 1703983 |
| 35 | -- | -- | -- | -- | -- | -- | -- | -- | -- |

Table 4-2. Decal Legend

| Item # | ANSI 1001143099-D | Australian 1001143100-D | Japanese 1001143101-D | Korean 1001143102-D | French 1001143103-D | Chinese 1001143104-D | Portuguese/ Spanish 1001143105-D | CE 1001143106-D | English/ Spanish 1001143107-D |
|---------------|------------------------------|------------------------------------|----------------------------------|--------------------------------|--------------------------------|---------------------------------|---|----------------------------|--|
| 36 | -- | -- | -- | -- | -- | -- | -- | -- | -- |
| 37 | -- | -- | -- | -- | -- | -- | -- | -- | -- |
| 38 | -- | -- | -- | -- | -- | -- | -- | -- | -- |
| 39 | -- | -- | -- | -- | 1705514 | -- | -- | -- | -- |
| 40 | -- | -- | -- | -- | -- | -- | -- | -- | -- |
| 41 | -- | -- | -- | -- | -- | -- | -- | -- | -- |
| 42 | -- | -- | -- | -- | -- | -- | -- | -- | -- |
| 43 | -- | -- | -- | -- | -- | -- | -- | -- | -- |
| 44 | 1001143110 | 1001143110 | 1001143110 | 1001143110 | 1001143110 | 1001143110 | 1001143110 | 1001143110 | 1001143110 |
| 45 | 1704885 | 1704885 | 1704885 | 1704885 | 1704885 | 1704885 | 1704885 | 1704885 | 1704885 |
| 46 | -- | -- | -- | -- | -- | -- | -- | -- | -- |
| 47 | -- | -- | -- | -- | -- | -- | -- | -- | -- |
| 48 | -- | -- | -- | -- | -- | -- | -- | -- | -- |
| 49 | -- | -- | -- | -- | -- | -- | -- | -- | -- |
| 50 | 1705351 | -- | 1705426 | 1705427 | 1705429 | 1705430 | 1705905 | -- | 1705910 |
| 51 | -- | 1001112551 | -- | -- | -- | -- | -- | -- | -- |
| 52 | -- | -- | -- | -- | -- | -- | -- | -- | -- |

SECTION 5. EMERGENCY PROCEDURES

5.1 GENERAL

This section explains the steps to be taken in case of an emergency situation while operating.

Failure to notify the manufacturer of an incident involving a JLG Industries product within 48 hours of such an occurrence may void any warranty consideration on that particular machine.

5.2 INCIDENT NOTIFICATION

JLG Industries, Inc. must be notified immediately of any incident involving a JLG product. Even if no injury or property damage is evident, the factory should be contacted by telephone and provided with all necessary details.

In USA:

JLG Phone: 877-JLG-SAFE (554-7233)

Outside USA:

240-420-2661

E-mail:

ProductSafety@JLG.com

NOTICE

FOLLOWING ANY ACCIDENT, THOROUGHLY INSPECT THE MACHINE AND TEST ALL FUNCTIONS FIRST FROM THE GROUND CONTROLS, THEN FROM THE PLATFORM CONTROLS. DO NOT LIFT ABOVE 10 FT. (3 M) UNTIL YOU ARE SURE THAT ALL DAMAGE HAS BEEN REPAIRED, IF REQUIRED, AND THAT ALL CONTROLS ARE OPERATING CORRECTLY.

5.3 EMERGENCY OPERATION

Operator Unable to Control Machine

IF THE PLATFORM OPERATOR IS PINNED, TRAPPED OR UNABLE TO OPERATE OR CONTROL MACHINE:

1. Other personnel should operate the machine from ground controls only as required.
2. Other qualified personnel on the platform may use the platform controls. DO NOT CONTINUE OPERATION IF CONTROLS DO NOT FUNCTION PROPERLY.
3. Cranes, forklift trucks or other equipment can be used to stabilize motion of the machine.

Platform or Boom Caught Overhead

If the platform or boom becomes jammed or snagged in overhead structures or equipment, rescue platform occupants prior to freeing the machine.

5.4 EMERGENCY TOWING PROCEDURES

Towing this machine is prohibited, unless properly equipped. However, provisions for moving the machine have been incorporated. For specific procedures, refer to Section 4.

5.5 MACHINE SAFETY SYSTEM OVERRIDE (MSSO)(CE ONLY)

The Machine Safety System Override (MSSO) is only to be used to retrieve an operator that is pinned, trapped, or unable to operate the machine and function controls are locked out from the platform due to a platform overload situation.



NOTE: *If the MSSO functionality is used, the fault indicator will flash and a fault code is set in the JLG Control System which must be reset by a qualified JLG Service Technician.*

NOTE: *No functional checks of the MSSO system are necessary. The JLG Control system will set a Diagnostic Trouble Code if the control switch is faulty.*

To operate the MSSO:

1. From the ground control console, place the Platform/ Ground Select switch in the Ground position.
2. Pull out the Power/Emergency Stop control.
3. Start the engine.
4. Press and hold the MSSO switch and the control switch for the desired function.

SECTION 6. GENERAL SPECIFICATIONS AND OPERATOR MAINTENANCE

6.1 INTRODUCTION

This section of the manual provides additional necessary information to the operator for proper operation and maintenance of this machine.

The maintenance portion of this section is intended as information to assist the machine operator to perform daily maintenance tasks only, and does not replace the more thorough Preventive Maintenance and Inspection Schedule included in the Service and Maintenance Manual.

Other Publications Available:

450A/450AJ Service and Maintenance Manual.....3121290

450A/450AJ Illustrated Parts Manual3121291

6.2 OPERATING SPECIFICATIONS AND PERFORMANCE DATA

Table 6-1. Operating Specifications

| | |
|--|------------------------------------|
| Unrestricted Rated Capacity ANSI CE & Australia | 500 lb (227 kg) 500 lb (230 kg) |
| Maximum Travel Grade (Gradeability) with Boom retracted and approximately horizontal. Tower Boom fully lowered (if equipped). 2WD 4WD | 30% 45% |
| Maximum Travel Grade (Sideslope) with Boom retracted and approximately horizontal. Tower Boom fully lowered (if equipped) - ANSI Markets. | 5° |
| Maximum Travel Grade (Sideslope) with Boom retracted and approximately horizontal. Tower Boom fully lowered (if equipped) - CE & Australia Markets. | 4° |

SECTION 6 - GENERAL SPECIFICATIONS AND OPERATOR MAINTENANCE

Table 6-1. Operating Specifications

| | |
|---------------------------------|-----------------------------------|
| Ground Bearing Pressure | |
| Pneumatic | 65 psi (4.57 kg/cm ²) |
| Foam Filled | 65 psi (4.57 kg/cm ²) |
| Maximum Drive Speed: | 4.5 mph (2.0 m/s) |
| Maximum Hyd. Operating Pressure | 4500 psi (310 bar) |
| Electrical System Voltage | 12 volts |

Reach Specifications

Table 6-2. Reach Specifications

| | |
|---------------------------------|------------------------|
| Max. Platform Height | 45ft (13.72 m) |
| Max. Horizontal Reach-450A SII | 24ft-7.25 in. (7.50 m) |
| Max. Horizontal Reach-450AJ SII | 24ft-6in (7.47 m) |
| Up & Over Height-450A SII | 25 ft-9.5 in (7.56 m) |
| Up & Over Height-450AJ SII | 25 ft-10 in (7.57 m) |
| Main Boom Up Angle | 75° |
| Main Boom Down Angle | -24° |

Dimensional Data

Table 6-3. Dimensional Data

| | |
|-------------------------|------------------------|
| Overall Width | 7 ft-8.25 in (2.34 m) |
| Tailswing | 0 |
| Stowed Height | 7 ft-6 in (2.29 m) |
| Stowed Length-450A SII | 21 ft-11 in (6.68 m) |
| Stowed Length-450AJ SII | 22 ft-0.25 in (6.71 m) |
| Wheel base | 7 ft-8 in (2.34 m) |
| Ground Clearance | 11.5 in (0.29 m) |

Chassis

Table 6-4. Chassis Specifications

| | |
|--|-----------------------|
| Swing | 360° non-continuous |
| Rated Gradeability | |
| 2WD | 30% |
| 4WD | 45% |
| Max. Tire Load | 7200 lb (3266 kg) |
| Axle Oscillation | 8 in (0.2 m) |
| System Voltage | 12 Volts |
| Max. Hydraulic System Operating Pressure | 4500 psi (310 bar) |
| Gross Machine Weight - 450A SII | |
| Pneumatic Tires | 12,750 lb (5783 kg) |
| Foam-Filled Tires | 13,660 lb (6196 kg) |
| Gross Machine Weight - 450AJ SII | |
| Pneumatic Tires | 13,250 lb (6010 kg) |
| Foam-Filled Tires | 14,160 lb (6423 kg) |

SECTION 6 - GENERAL SPECIFICATIONS AND OPERATOR MAINTENANCE

Major Component Weights

Table 6-5. Component Weights

| Component | lb | kg |
|--------------------|------|------|
| Frame (Bare) | 1531 | 695 |
| Turntable (Bare) | 1355 | 615 |
| Boom Link | 180 | 82 |
| Boom Timing Link | 30 | 14 |
| Upper Upright | 217 | 98 |
| Lower Upright | 115 | 52 |
| Lower Boom | 497 | 225 |
| Mid Boom | 385 | 175 |
| Upper Boom | 1065 | 484 |
| 4 Wheel Drive Axle | 266 | 121 |
| 2 Wheel Drive Axle | 258 | 117 |
| Counterweight | 2297 | 1042 |

Capacities

Table 6-6. Capacities

| | |
|----------------|---|
| Fuel Tank | 17 gal (64.3 L) |
| Hydraulic Tank | 27 gal (102 L) 23.6 gal (89 L) to the mid point of upper sight window (cold) |
| Drive Hub | 23.75 oz (0.7 L) |
| Drive Brake | 2.7 oz (0.08 L) |

Tires

Table 6-7. Tires

| Size | Type | Pressure | Weight |
|--------------|-------------|----------------|------------------|
| 12x16.5 | Pneumatic | 90 psi (6 bar) | 128 lb (58 kg) |
| 12x16.5 | Foam-Filled | N/A | 328 lb (149 kg) |
| 33/1550x16.5 | Pneumatic | 90 psi (6 bar) | 135 lb (61 kg) |
| 33/1550x16.5 | Foam-Filled | N/A | 395 lb (179 kg) |
| 14x17.5 | Pneumatic | 90psi (6 bar) | 170 lb (77.2 kg) |
| 14x17.5 | Foam-Filled | N/A | 440 lb (200 kg) |

SECTION 6 - GENERAL SPECIFICATIONS AND OPERATOR MAINTENANCE

Engine

NOTE: RPM Tolerances are ± 100 .

Table 6-8. Caterpillar C2.2

| | |
|-------------------|-------------------------------|
| Fuel | Diesel |
| No. of Cylinders | 4 |
| BHP | 46.5 hp (34 kW) |
| Bore | 3.307 in (84 mm) |
| Stroke | 3.9370 in (112 mm) |
| Displacement | 134.3 cu. in (2.2 L) |
| Oil Capacity | 3.8 qt (3.6 L) crankcase only |
| Compression Ratio | 19:1 |
| Firing Order | 1-3-4-2 |
| Max. RPM | 2800 |

Table 6-9. Deutz TCD2.9L4

| | |
|---------------------------|------------------------------------|
| Type | Liquid Cooled |
| Number of Cylinders | 4 |
| Bore | 3.6 in (92 mm) |
| Stroke | 4.3 in (110 mm) |
| Total Displacement | 178 cu. in (2925 cm ³) |
| Firing Order | 1-3-4-2 |
| Output | 74.2 hp (55.4 kW) |
| Oil Capacity | 2.4 gal (8.9 L) |
| Coolant Capacity (System) | 3.2 gal (12.1 L) |
| Average Fuel Consumption | 1.2 gph (4.1 Lph) |
| Min. Low Engine RPM | 1200 |
| Mid Engine RPM | 1800 |
| Max. High Engine RPM | 2500 |

SECTION 6 - GENERAL SPECIFICATIONS AND OPERATOR MAINTENANCE

Table 6-10. Deutz D2011L03

| | |
|------------------------------|------------------------------------|
| Fuel | Diesel |
| No. of Cylinders | 3 |
| Bore | 3.7 in (94 mm) |
| Stroke | 4.4 in (112 mm) |
| Displacement | 142 cu. in (2331 cm ³) |
| Oil Capacity | |
| crankcase | 6.3 qt (6 L) |
| cooler | 4.75 qt (4.5 L) |
| total capacity | 11 qt (10.5 L) |
| Low RPM | 1200 |
| Mid RPM | |
| Tower Lift, Upper Lift, Tele | |
| Swing, Basket Level, Basket | 1800 |
| Rotate, Jib Lift | 1500 |
| High RPM | 2800 |

Table 6-11. GM 3.0L

| | |
|----------------------|-----------------------------|
| Fuel | Gasoline or Gasoline/LP Gas |
| No. of Cylinders | 4 |
| BHP | |
| Gasoline | 83 hp @ 3000 rpm |
| LP | 75 hp @ 3000 rpm |
| Bore | 4.0 in (101.6 mm) |
| Stroke | 3.6 in (91.44 mm) |
| Displacement | 181 cu.in(3.0L, 2966 cc) |
| Oil Capacityw/filter | 4.5 qt (4.25 L) |
| Minimum Oil Pressure | |
| at idle | 6 psi (0.4 bar) @ 1000 rpm |
| Hot | 18 psi (1.2 bar) @ 2000 rpm |
| Compression Ratio | 9.2:1 |
| Firing Order | 1-3-4-2 |
| Max. RPM | 2800 |

Hydraulic Oil

Table 6-12. Hydraulic Oil

| Hydraulic System Operating Temperature Range | S.A.E. Viscosity Grade |
|--|------------------------|
| +0°to+ 180°F (-18°to +83°C) | 10W |
| +0°to+ 210°F (-18°to +99°C) | 10W-20, 10W30 |
| +50°to+ 210°F (+10°to +99°C) | 20W-20 |

NOTE: Hydraulic oils must have anti-wear qualities at least to API Service Classification GL-3, and sufficient chemical stability for mobile hydraulic system service. JLG Industries recommends Mobilfluid 424 hydraulic oil, which has an SAE viscosity index of 152.

NOTE: When temperatures remain consistently below 20 degrees F. (-7 degrees C.), JLG Industries recommends the use of Mobil DTE13.

Aside from JLG recommendations, it is not advisable to mix oils of different brands or types, as they may not contain the same required additives or be of comparable viscosities. If use of hydraulic oil other than Mobilfluid 424 is desired, contact JLG Industries for proper recommendations.

Table 6-13. Mobilfluid 424 Specs

| SAE Grade | 10W30 |
|-------------------------|---------------|
| Gravity, API | 29.0 |
| Density, Lb/Gal. 60°F | 7.35 |
| Pour Point, Max | -46°F (-43°C) |
| Flash Point, Min. | 442°F (228°C) |
| Viscosity | |
| Brookfield, cP at -18°C | 2700 |
| at 40°C | 55 cSt |
| at 100°C | 9.3 cSt |
| Viscosity Index | 152 |

SECTION 6 - GENERAL SPECIFICATIONS AND OPERATOR MAINTENANCE

Table 6-14. Mobil DTE 13M Specs

| | |
|---------------------|---------------|
| ISO Viscosity Grade | #32 |
| Specific Gravity | 0.877 |
| Pour Point, Max | -40°F (-40°C) |
| Flash Point, Min. | 330°F (166°C) |
| Viscosity | |
| at 40°C | 33cSt |
| at 100°C | 6.6cSt |
| at 100°F | 169SUS |
| at 210°F | 48SUS |
| cp at -20°F | 6,200 |
| Viscosity Index | 140 |

Table 6-15. UCon Hydrolube HP-5046

| | |
|------------------|-------------------------|
| Type | Synthetic Biodegradable |
| Specific Gravity | 1.082 |
| Pour Point, Max | -58°F (-50°C) |
| pH | 9.1 |
| Viscosity | |
| at 0°C (32°F) | 340 cSt (1600SUS) |
| at 40°C (104°F) | 46 cSt (215SUS) |
| at 65°C (150°F) | 22 cSt (106SUS) |
| Viscosity Index | 170 |

SECTION 6 - GENERAL SPECIFICATIONS AND OPERATOR MAINTENANCE

Table 6-16. Mobil EAL H 46 Specs

| | |
|---------------------|---------------------------|
| Type | Synthetic Biodegradable |
| ISO Viscosity Grade | 46 |
| Specific Gravity | .910 |
| Pour Point | -44°F (-42°C) |
| Flash Point | 500°F (260°C) |
| Operating Temp. | 0 to 180°F (-17 to 162°C) |
| Weight | 7.64 lb/gal (0.9 kg/L) |
| Viscosity | |
| at 40°C | 45 cSt |
| at 100°C | 8.0 cSt |
| Viscosity Index | 153 |

Table 6-17. Exxon Univis HVI 26 Specs

| | |
|---|---------------|
| Specific Gravity | 32.1 |
| Pour Point | -76°F (-60°C) |
| Flash Point | 217°F (103°C) |
| Viscosity | |
| at 40°C | 25.8 cSt |
| at 100°C | 9.3 cSt |
| Viscosity Index | 376 |
| NOTE: Mobil/Exxon recommends that this oil be checked on a yearly basis for viscosity. | |

SECTION 6 - GENERAL SPECIFICATIONS AND OPERATOR MAINTENANCE

Table 6-18. Quintolubric 888-46

| | |
|--------------------------|--------------------|
| Density | 0.91 @ 15°C (59°F) |
| Pour Point | <-20°C (<-4°F) |
| Flash Point | 275°C (527°F) |
| Fire Point | 325°C (617°F) |
| Autoignition Temperature | 450°C (842°F) |
| Viscosity | |
| at 0°C (32°F) | 360 cSt |
| at 20°C (68°F) | 102 cSt |
| at 40°C (104°F) | 46 cSt |
| at 100°C (212°F) | 10 cSt |
| Viscosity Index | 220 |

Serial Number Location

A serial number plate is affixed to the left rear side of the frame. If the serial number plate is damaged or missing, the machine serial number is stamped on the left side of the frame.

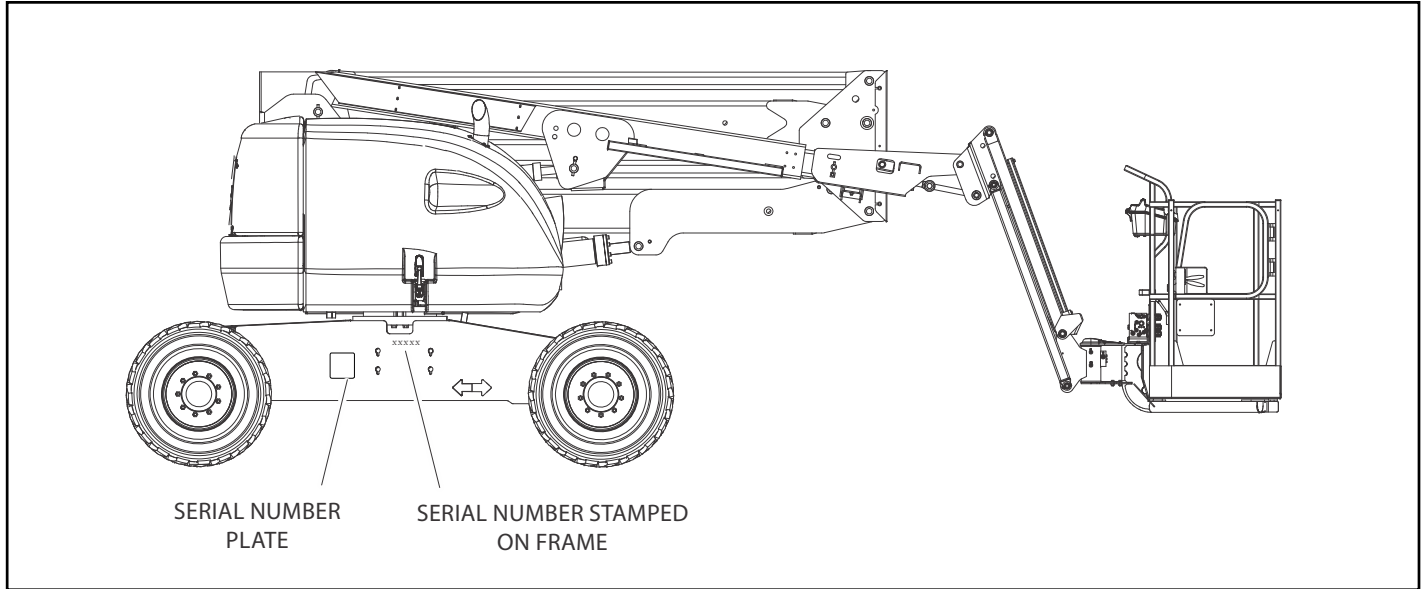

Figure 6-1. Serial Number Locations

SECTION 6 - GENERAL SPECIFICATIONS AND OPERATOR MAINTENANCE

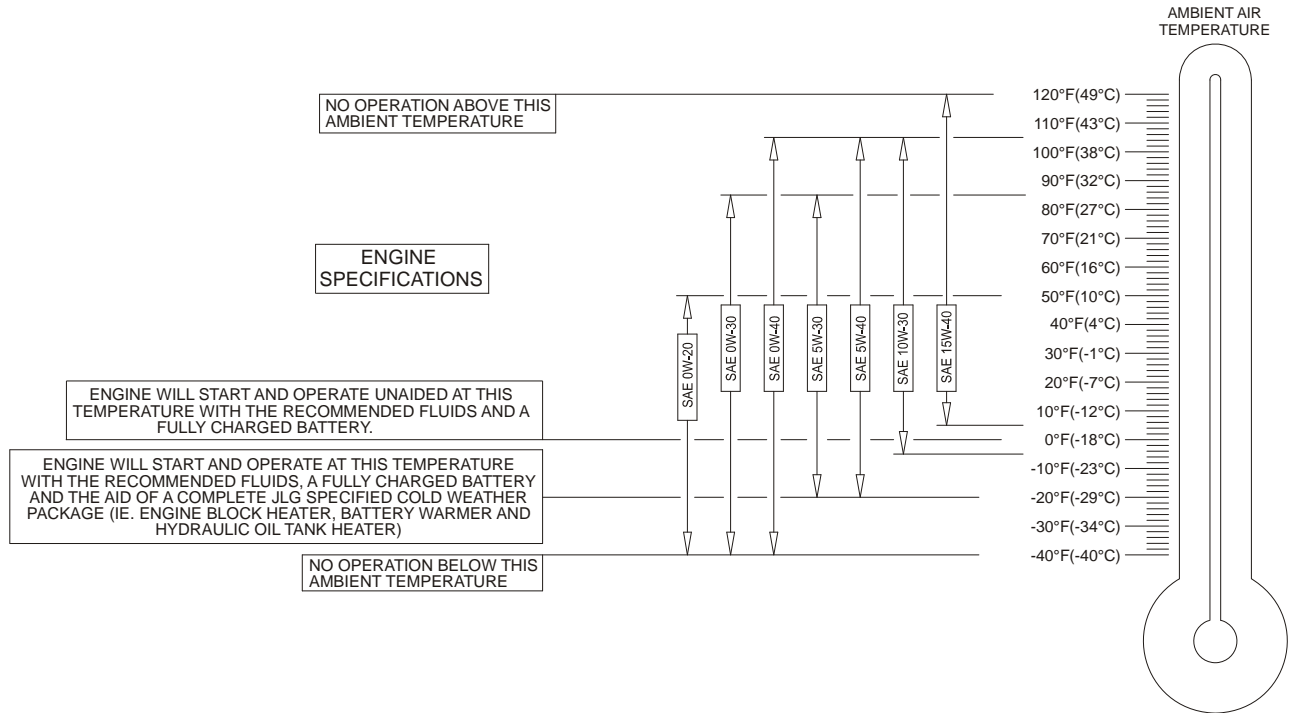
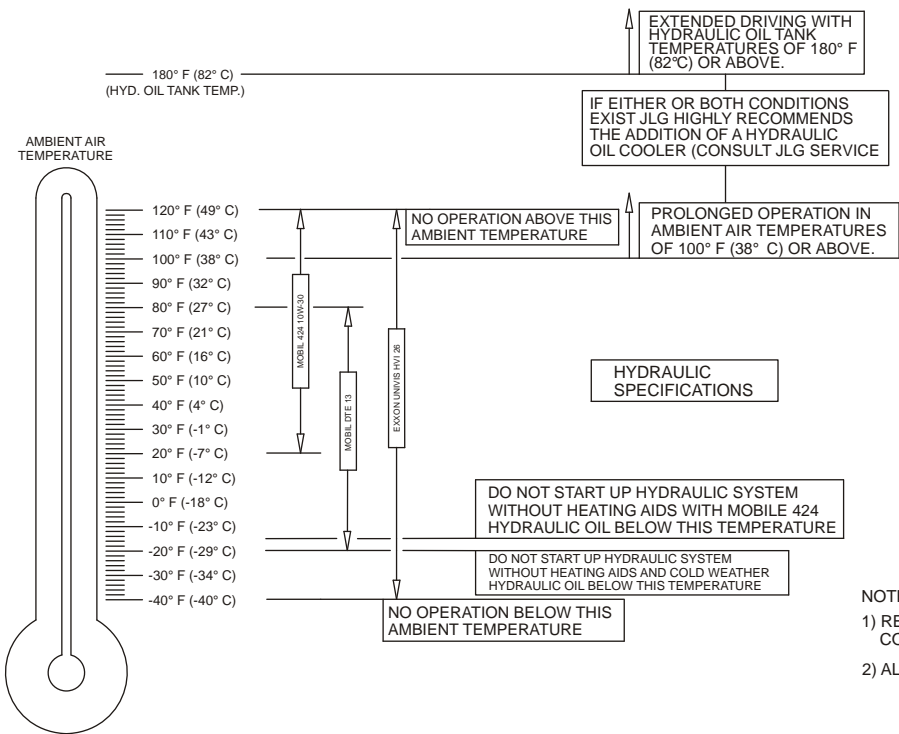

Figure 6-2. Engine Operating Temperature Specifications - Caterpillar - Sheet 1 of 2

SECTION 6 - GENERAL SPECIFICATIONS AND OPERATOR MAINTENANCE



NOTE:

- 1) RECOMMENDATIONS ARE FOR AMBIENT TEMPERATURES CONSISTENTLY WITHIN SHOWN LIMITS
- 2) ALL VALUES ARE ASSUMED TO BE AT SEA LEVEL.

Figure 6-3. Engine Operating Temperature Specifications - Caterpillar - Sheet 2 of 2

4150548-E

SECTION 6 - GENERAL SPECIFICATIONS AND OPERATOR MAINTENANCE

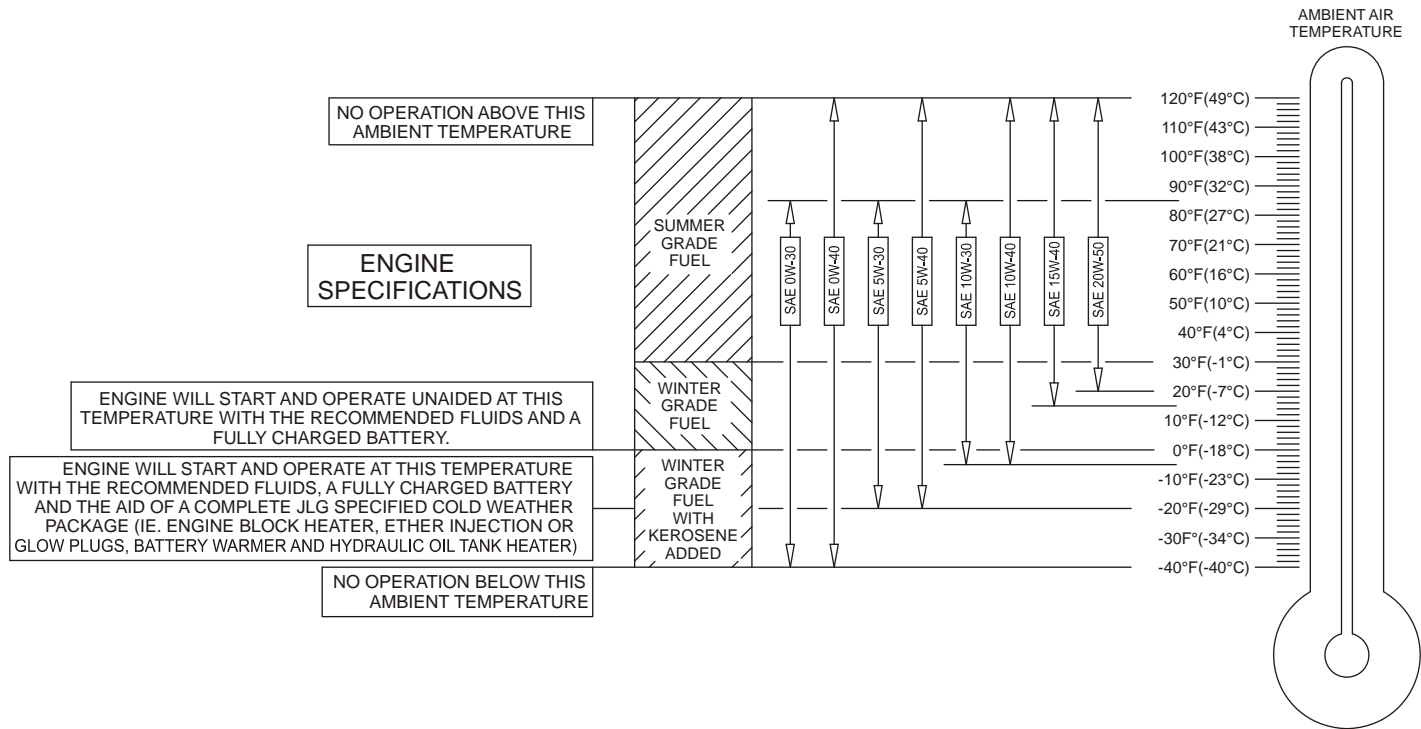

Figure 6-4. Engine Operating Temperature Specifications - Deutz - Sheet 1 of 2

SECTION 6 - GENERAL SPECIFICATIONS AND OPERATOR MAINTENANCE

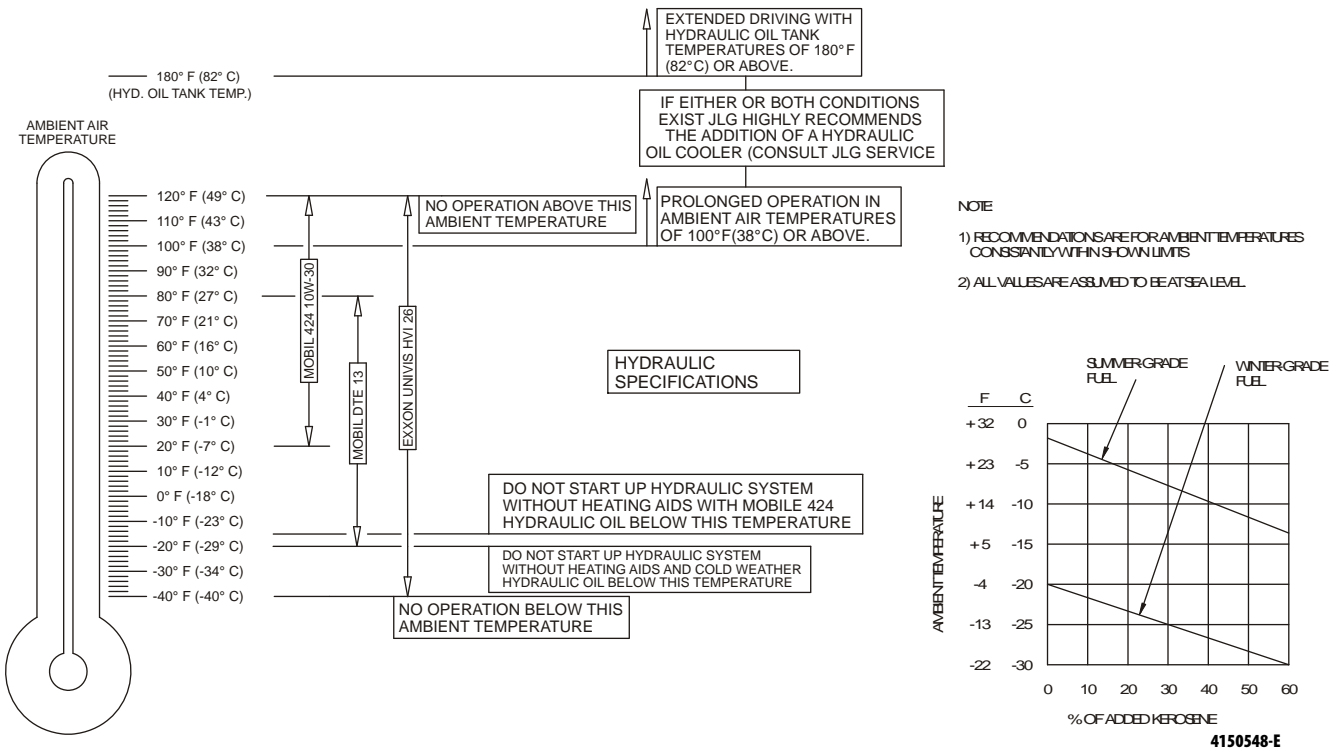

Figure 6-5. Engine Operating Temperature Specifications - Deutz - Sheet 2 of 2

SECTION 6 - GENERAL SPECIFICATIONS AND OPERATOR MAINTENANCE

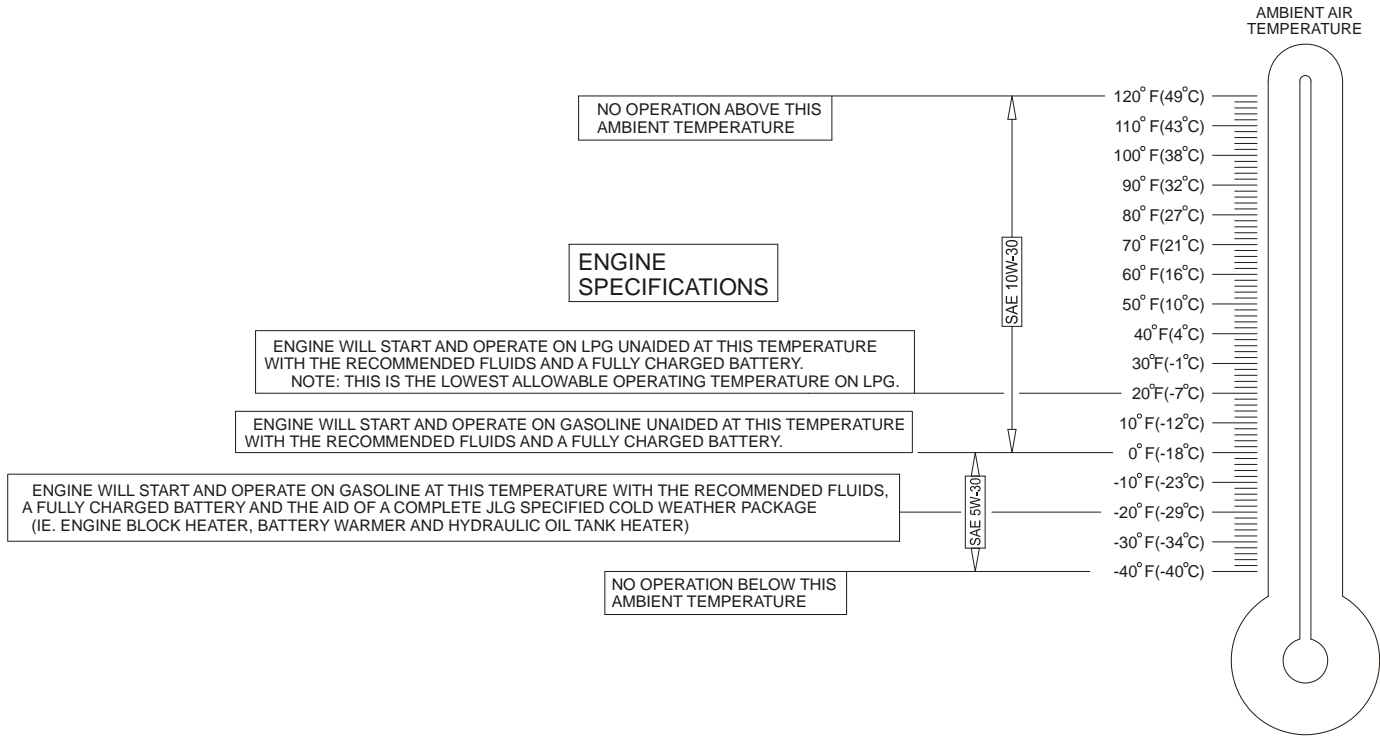

Figure 6-6. Engine Operating Temperature Specifications - GM - Sheet 1 of 2

SECTION 6 - GENERAL SPECIFICATIONS AND OPERATOR MAINTENANCE

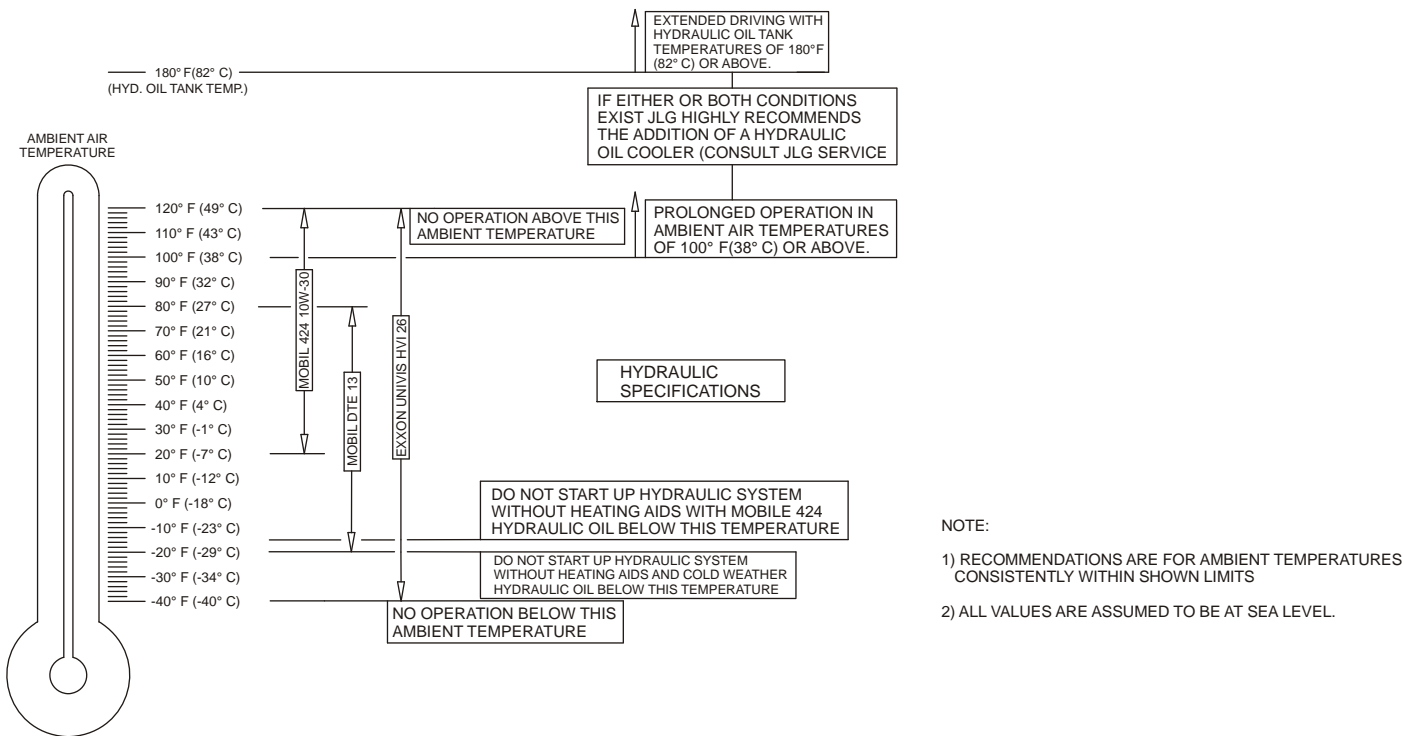

Figure 6-7. Engine Operating Temperature Specifications - GM - Sheet 2 of 2

4150548-E

SECTION 6 - GENERAL SPECIFICATIONS AND OPERATOR MAINTENANCE

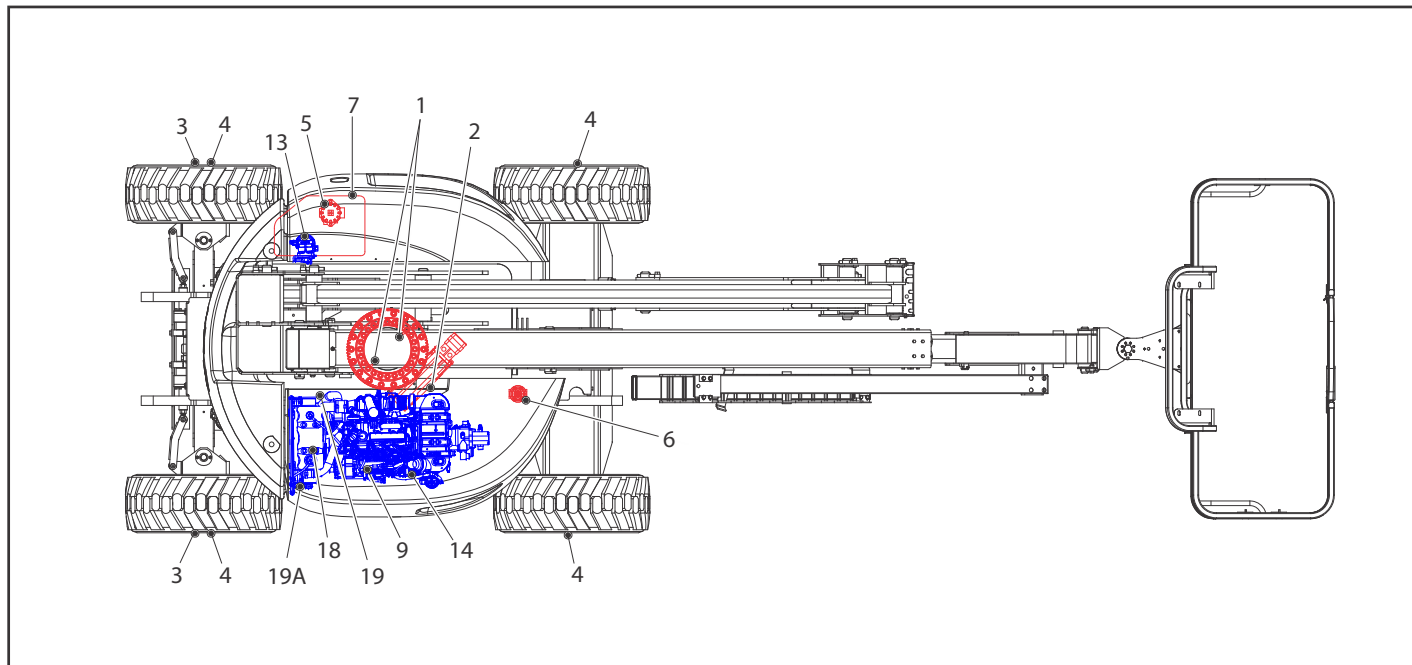

Figure 6-8. Operator Maintenance and Lubrication Diagram - Deutz D2.9

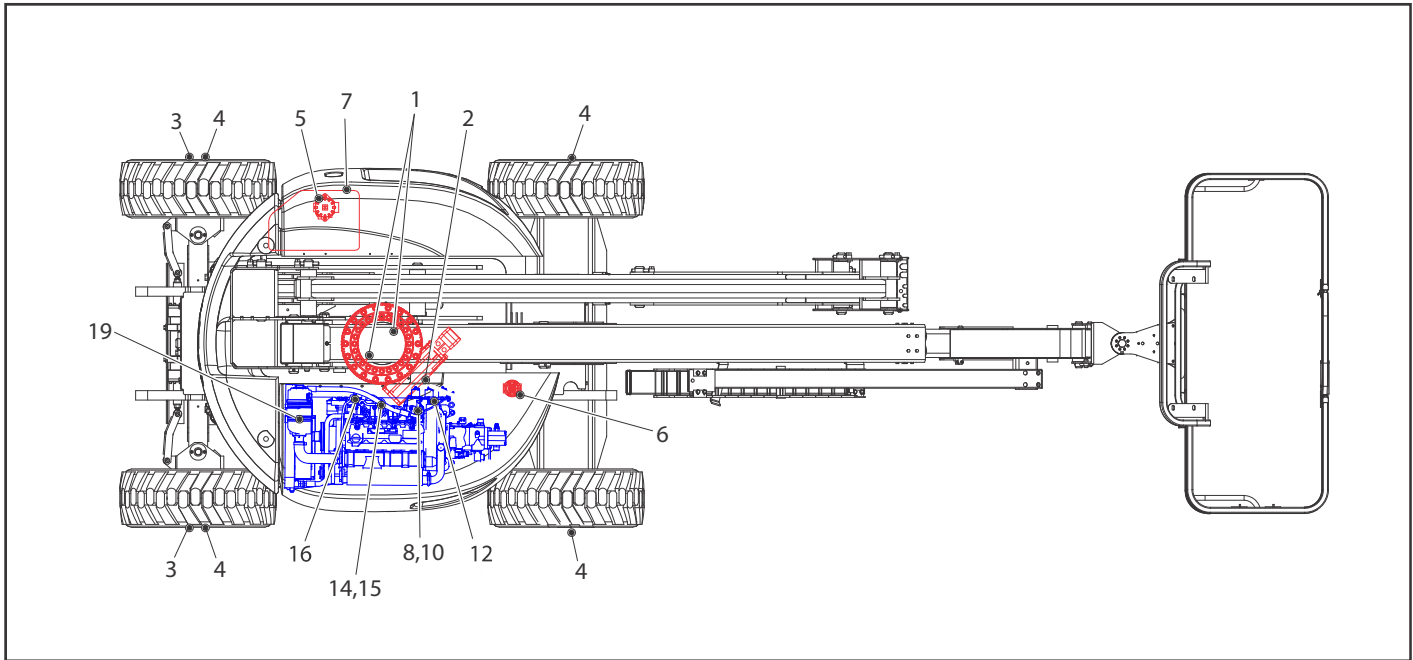

Figure 6-9. Operator Maintenance and Lubrication Diagram - Deutz D2011 and CAT C2.2

SECTION 6 - GENERAL SPECIFICATIONS AND OPERATOR MAINTENANCE

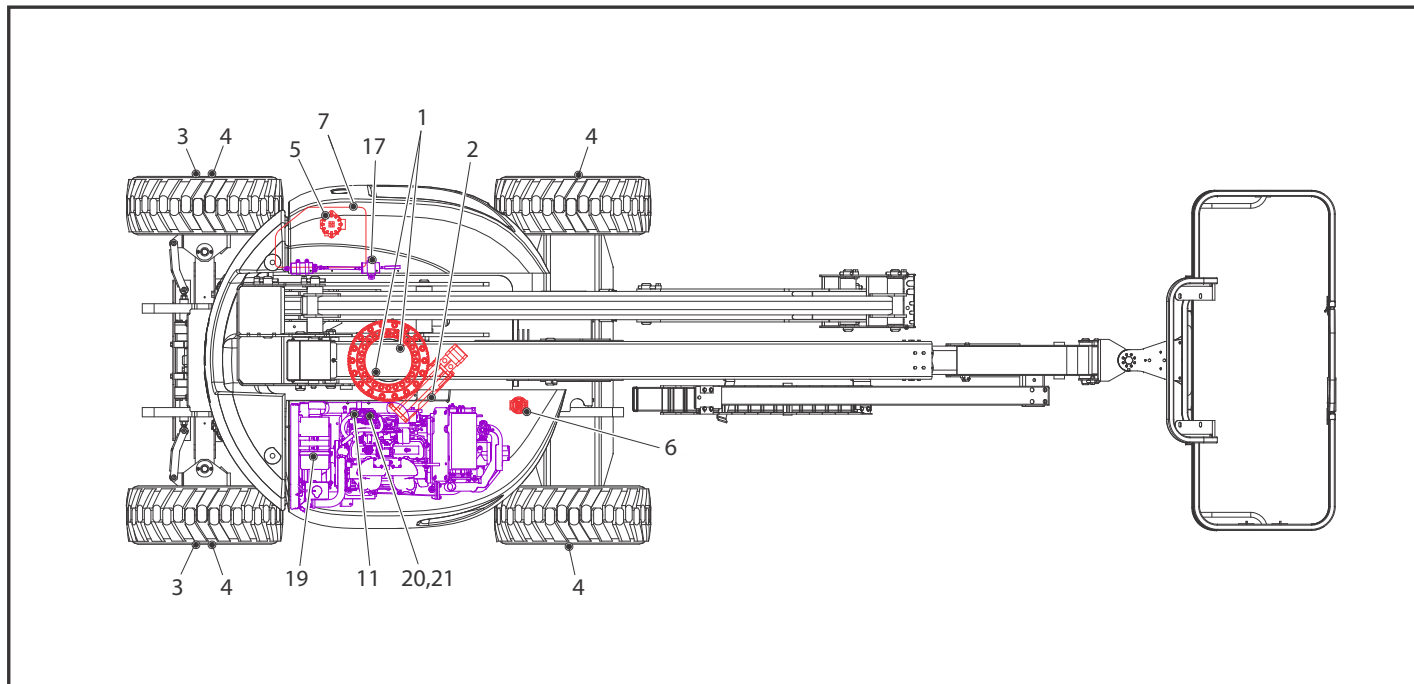

Figure 6-10. Operator Maintenance and Lubrication Diagram - GM Dual-Fuel

6.3 OPERATOR MAINTENANCE

NOTE: The following numbers correspond to those in Figure 6-8., Operator Maintenance and Lubrication Diagram - Deutz D2.9, Figure 6-9., Operator Maintenance and Lubrication Diagram - Deutz D2011 and CAT C2.2, Figure 6-10., Operator Maintenance and Lubrication Diagram - GM Dual-Fuel.

Table 6-19. Lubrication Specifications

| KEY | SPECIFICATIONS |
|------|---|
| MPG | Multipurpose Grease having a minimum dripping point of 350°F (177°C). Excellent water resistance and adhesive qualities, and being of extreme pressure type. (Timken OK 40 pounds minimum.) |
| EPGL | Extreme Pressure Gear Lube (oil) meeting API service classification GL-5 or MIL-Spec MIL-L-2105 |
| HO | Hydraulic Oil. API service classification GL-3, e.g. Mobilfluid 424. |
| EO | Engine (crankcase) Oil. Gas - API SF, SH, SG class, MIL-L-2104. Diesel - API CC/CD class, MIL-L-2104B/MIL-L-2104C. |
| OGL | Open Gear Lubricant - Mobilvac 375 or equivalent. |

NOTICE

LUBRICATION INTERVALS ARE BASED ON MACHINE OPERATION UNDER NORMAL CONDITIONS. FOR MACHINES USED IN MULTI-SHIFT OPERATIONS AND/OR EXPOSED TO HOSTILE ENVIRONMENTS OR CONDITIONS, LUBRICATION FREQUENCIES MUST BE INCREASED ACCORDINGLY.

NOTE: It is recommended as a good practice to replace all filters at the same time.

1. Swing Bearing - Internal Ball Bearing
 Lube Point(s) - 2 Grease Fittings
 Capacity - A/R
 Lube - MPG
 Interval - Every 3 months or 150 hrs of operation

SECTION 6 - GENERAL SPECIFICATIONS AND OPERATOR MAINTENANCE

2. Swing Bearing/Worm Gear Teeth

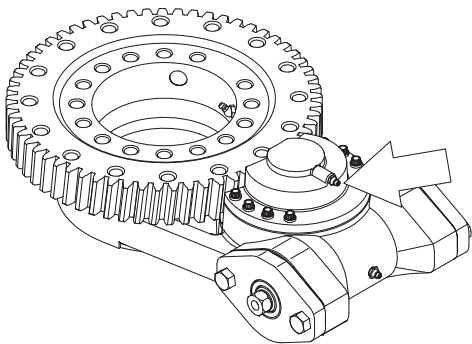

Lube Point(s) - Grease Fitting
Capacity - A/R
Lube - Lubriplate 930-AAA
Interval - A/R

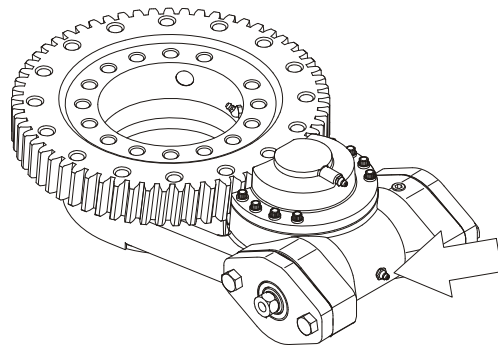

Lube Point(s) - Grease Fitting*
Capacity - A/R
Lube - Mobile SHC 007
Interval - A/R

⚠ CAUTION

DO NOT OVERGREASE BEARINGS. OVERGREASING BEARINGS WILL RESULT IN DAMAGE TO OUTER SEAL IN HOUSING.

*If necessary install grease fitting into worm gear housing and grease. Replace fitting with pipe plug when complete.

SECTION 6 - GENERAL SPECIFICATIONS AND OPERATOR MAINTENANCE

3. Wheel Bearings (2WD Only)

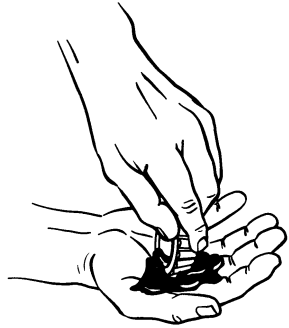

Lube Point(s) - Repack

Capacity - A/R

Lube - MPG

Interval - Every 2 years or 1200 hours of operation

4. Wheel Drive Hub

Lube Point(s) - Level/Fill Plug

Capacity - 17 oz (0.5 L) - 1/2 Full

Lube - EPGL

Interval - Check level every 3 months or 150 hours of operation; change every 2 years or 1200 hours of operation.

5. Hydraulic Return Filter

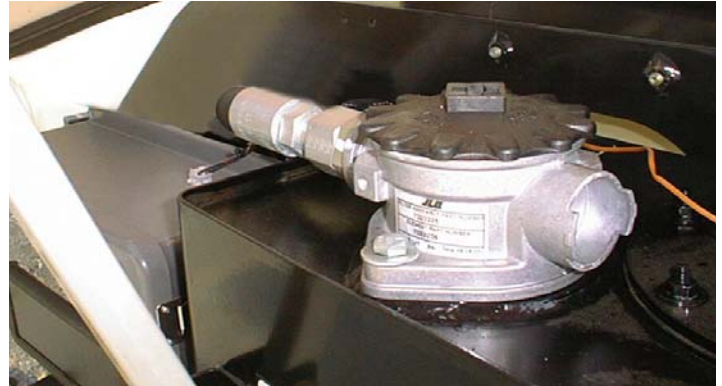

Interval - Change after first 50 hours and every 6 months or 300 hours thereafter or as indicated by Condition Indicator.

SECTION 6 - GENERAL SPECIFICATIONS AND OPERATOR MAINTENANCE

6. Hydraulic Charge Filter



Interval - Change after first 50 hours and every 6 months or 300 hours thereafter or as indicated by Condition Indicator.

7. Hydraulic Tank

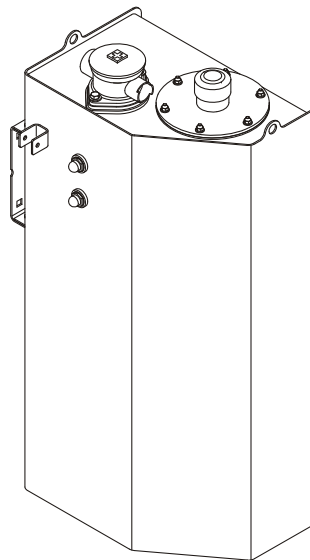

Lube Point(s) - Fill Cap

Capacity - 27 gal (102 L); 23.6 gal (89 L) to mid point of upper sight window (cold)

Lube - HO

Interval - Check Level daily; Change every 2 years or 1200 hours of operation.

SECTION 6 - GENERAL SPECIFICATIONS AND OPERATOR MAINTENANCE

8. Oil Change w/Filter - Caterpillar



Lube Point(s) - Fill Cap/Spin-on Element (JLG P/N 7026855)

Capacity - 10 qt (9.4 L)

Lube - EO

Interval - Every Year or 500 hours of operation

Comments - Check level daily/Change in accordance with engine manual.

9. Oil Change w/Filter - Deutz 2.9 L4

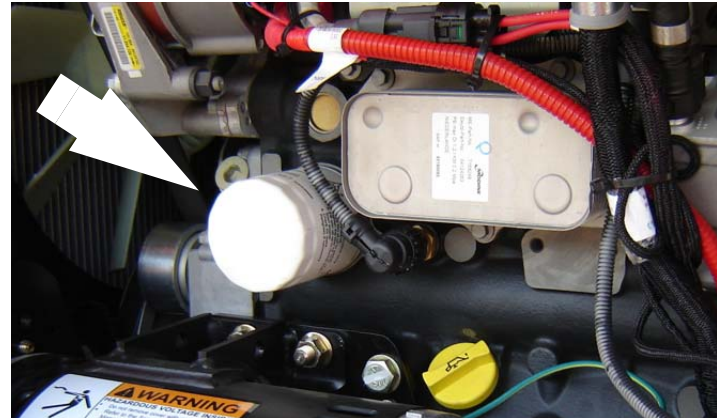

Lube Point(s) - Fill Cap/Spin-on Element

Capacity - 2.4 gal (8.9 L)

Lube - EO

Interval - Every Year or 600 hours of operation

Comments - Check level daily/Change in accordance with engine manual.

SECTION 6 - GENERAL SPECIFICATIONS AND OPERATOR MAINTENANCE

10. Oil Change w/Filter - Deutz D2011

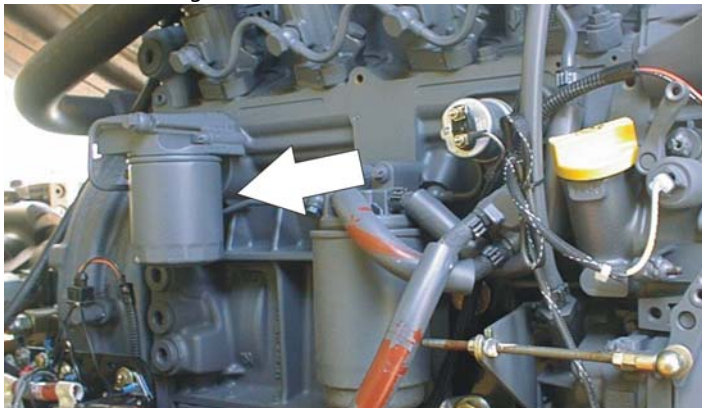

Fill Cap/Spin-on Element (JLG P/N
7016641)

Capacity - 11 qt (10.5 L) Crankcase; 5 qt (4.7 L)

Cooler

Lube - EO

Interval - Every Year or 1200 hours of operation

Comments - Check level daily/Change in accordance
with engine manual.

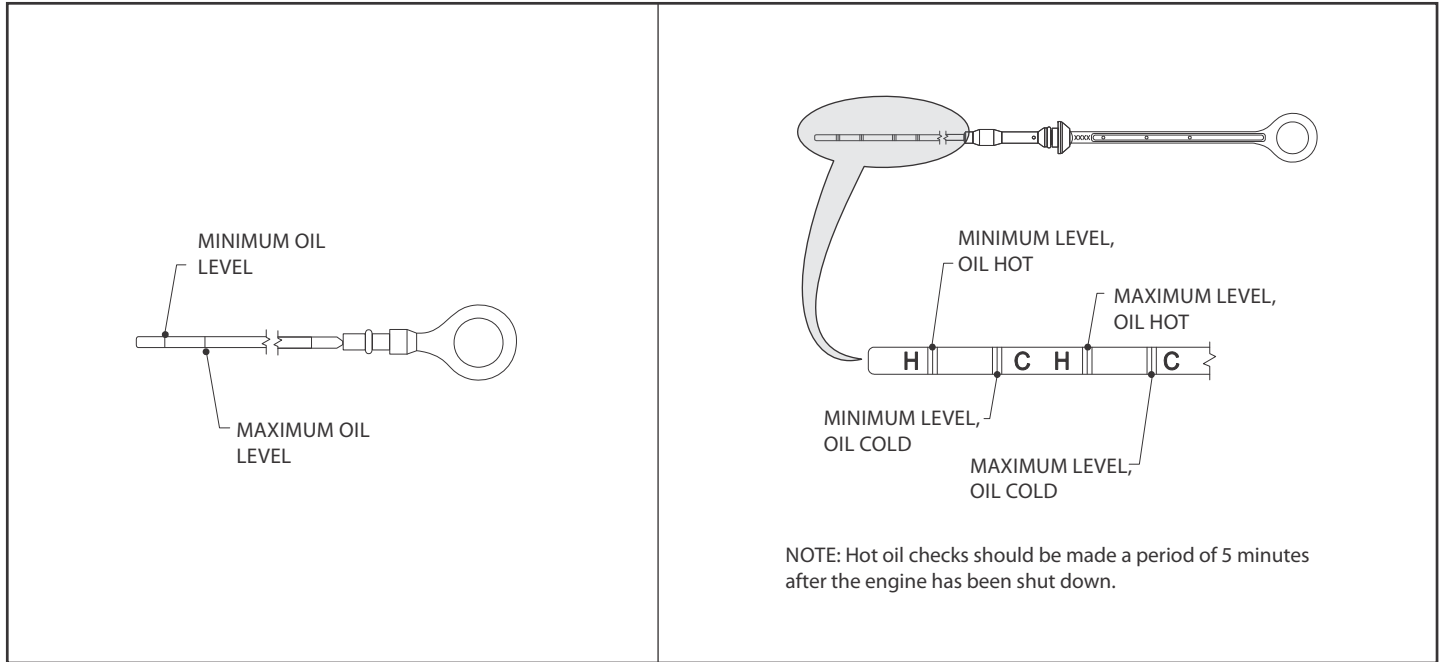
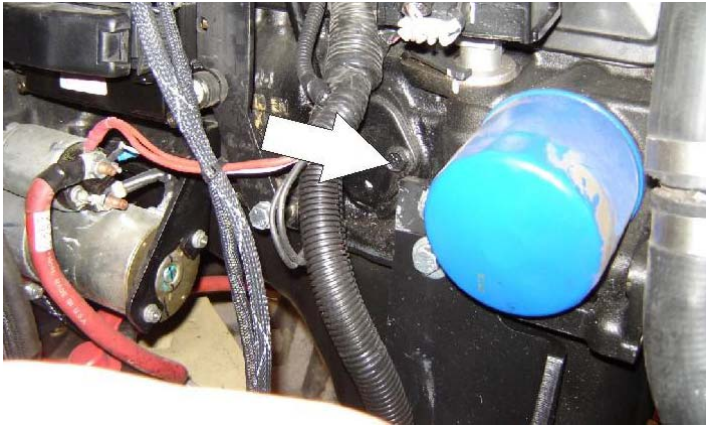

Figure 6-11. Deutz D2011 Engine Dipsticks

SECTION 6 - GENERAL SPECIFICATIONS AND OPERATOR MAINTENANCE

11. Oil Change w/Filter - GM



Lube Point(s) - Fill Cap/Spin-on Element
(JLG P/N 7027965)
Capacity - 4.5 qt (4.25 L) w/filter
Lube - EO
Interval - 3 Months or 150 hours of operation
Comments - Check level daily/Change in accordance
with engine manual.

12. Fuel Filter - Caterpillar



Lube Point(s) - Replaceable Element
Interval - Every Year or 600 hours of operation

SECTION 6 - GENERAL SPECIFICATIONS AND OPERATOR MAINTENANCE

13. Fuel Pre-Filter - Deutz D2.9



Lube Point(s) - Replaceable Element
Interval - Drain water daily; Every year or 600 hours of operation

14. Fuel Filter - Deutz D2.9



Lube Point(s) - Replaceable Element
Interval - Every year or 600 hours of operation

SECTION 6 - GENERAL SPECIFICATIONS AND OPERATOR MAINTENANCE

15. Fuel Strainer - Deutz D2011

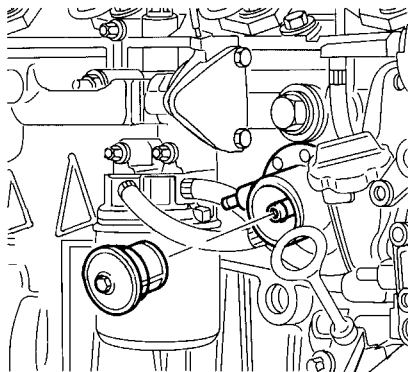

Lube Point(s) - Replaceable Element
Interval - Every Year or 600 hours of operation

16. Fuel Filter - Deutz D2011

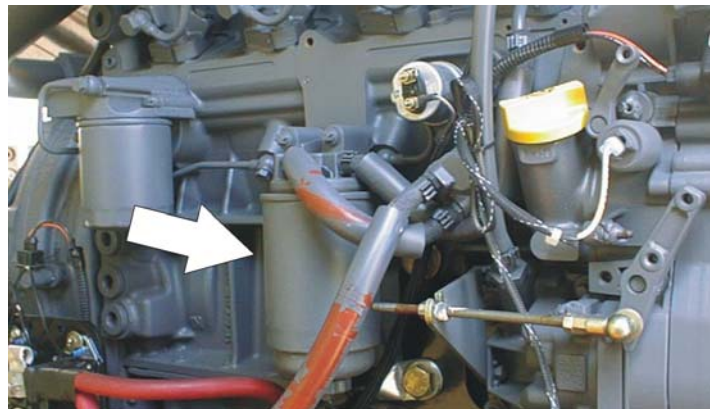

Lube Point(s) - Replaceable Element
Interval - Every Year or 600 hours of operation

SECTION 6 - GENERAL SPECIFICATIONS AND OPERATOR MAINTENANCE

17. Fuel Filter - GM

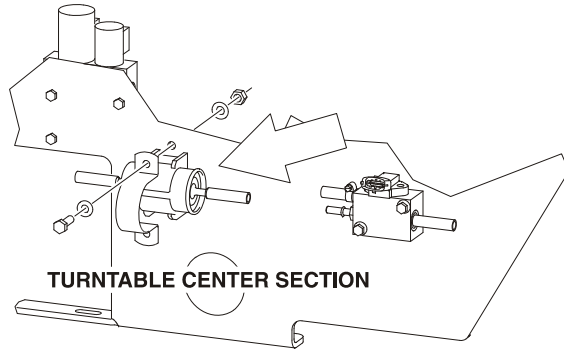

Lube Point(s) - Replaceable Element
Interval - Every 6 months or 300 hours of operation

18. Radiator Coolant Deutz 2.9



Lube Point(s) - Fill Cap
Capacity - 3.2 gal (12.1 L)
Lube - Anti-Freeze
Interval - Check level daily; change every 1000 hours or 2 years, whichever comes first.

SECTION 6 - GENERAL SPECIFICATIONS AND OPERATOR MAINTENANCE

19. Air Filter



DEUTZ D2011, GM

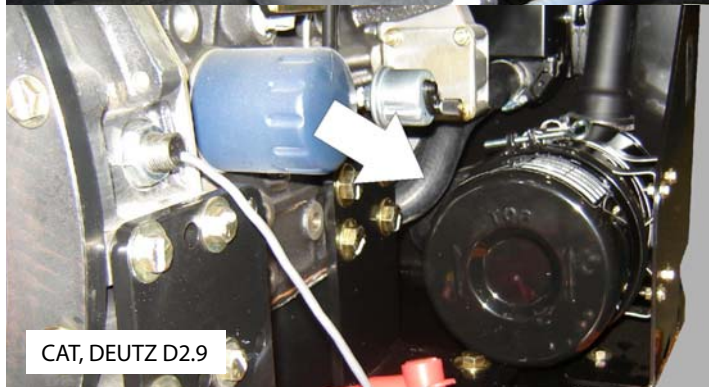

CAT, DEUTZ D2.9

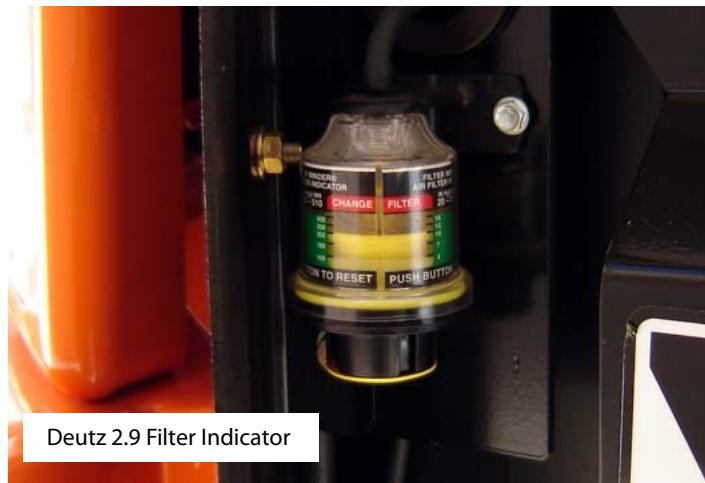

Deutz 2.9 Filter Indicator

Lube Point(s) - Replaceable Element
Interval - Every 6 months or 300 hours of operation or as indicated by the condition indicator (19A)

20. Electronic Pressure Regulator (LP only)

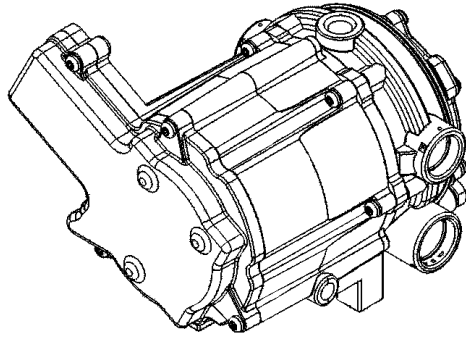

Interval - 3 Months or 150 hours of operation
Comments - Drain oil build up. Refer to Section 6.5, Propane Fuel Filter Replacement.

21. Fuel Filter (Propane) - GM Engine

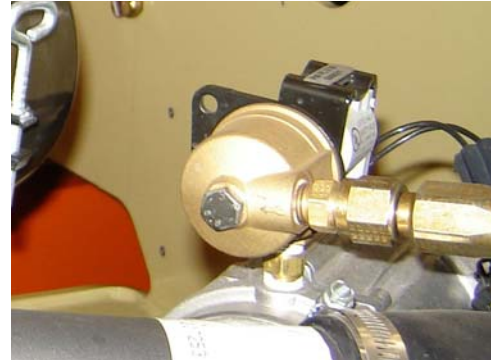

Interval - 3 Months or 150 hours of operation
Comments - Replace filter. Refer to Section 6.5, Propane Fuel Filter Replacement.

6.4 TIRES & WHEELS

Tire Inflation

The air pressure for pneumatic tires must be equal to the air pressure that is stenciled on the side of the JLG product or rim decal for safe and proper operational characteristics.

Tire Damage

For pneumatic tires, JLG Industries, Inc. recommends that when any cut, rip, or tear is discovered that exposes sidewall or tread area cords in the tire, measures must be taken to remove the JLG product from service immediately. Arrangements must be made for replacement of the tire or tire assembly.

For polyurethane foam filled tires, JLG Industries, Inc. recommends that when any of the following are discovered, measures must be taken to remove the JLG product from service immediately and arrangements must be made for replacement of the tire or tire assembly.

- a smooth, even cut through the cord plies which exceeds 3 inches (7.5 cm) in total length
- any tears or rips (ragged edges) in the cord plies which exceeds 1 inch (2.5 cm) in any direction
- any punctures which exceed 1 inch in diameter

- any damage to the bead area cords of the tire

If a tire is damaged but is within the above noted criteria, the tire must be inspected on a daily basis to insure the damage has not propagated beyond the allowable criteria.

Tire Replacement

JLG recommends a replacement tire be the same size, ply and brand as originally installed on the machine. Please refer to the JLG Parts Manual for the part number of the approved tires for a particular machine model. If not using a JLG approved replacement tire, we recommend that replacement tires have the following characteristics:

- Equal or greater ply/load rating and size of original
- Tire tread contact width equal or greater than original
- Wheel diameter, width, and offset dimensions equal to the original
- Approved for the application by the tire manufacturer (including inflation pressure and maximum tire load)

Unless specifically approved by JLG Industries Inc. do not replace a foam filled or ballast filled tire assembly with a pneumatic tire. When selecting and installing a replacement tire, ensure that all tires are inflated to the pressure recommended by JLG. Due to size variations between tire brands, both tires on the same axle should be the same.

Wheel and Tire Replacement

The rims installed on each product model have been designed for stability requirements which consist of track width, tire pressure, and load capacity. Size changes such as rim width, center piece location, larger or smaller diameter, etc., without written factory recommendations, may result in an unsafe condition regarding stability.

Wheel Installation

It is extremely important to apply and maintain proper wheel mounting torque.



WHEEL NUTS MUST BE INSTALLED AND MAINTAINED AT THE PROPER TORQUE TO PREVENT LOOSE WHEELS, BROKEN STUDS, AND POSSIBLE DANGEROUS SEPARATION OF WHEEL FROM THE AXLE. BE SURE TO USE ONLY THE NUTS MATCHED TO THE CONE ANGLE OF THE WHEEL.

Tighten the lug nuts to the proper torque to prevent wheels from coming loose. Use a torque wrench to tighten the fasteners. If you do not have a torque wrench, tighten the fasteners with a lug wrench, then immediately have a service garage or dealer tighten the lug nuts to the proper torque. Over-tightening will result in breaking the studs or permanently deforming the mounting stud holes in the wheels. The proper procedure for attaching wheels is as follows:

1. Start all nuts by hand to prevent cross threading. DO NOT use a lubricant on threads or nuts.

SECTION 6 - GENERAL SPECIFICATIONS AND OPERATOR MAINTENANCE

2. Tighten nuts in the following sequence:

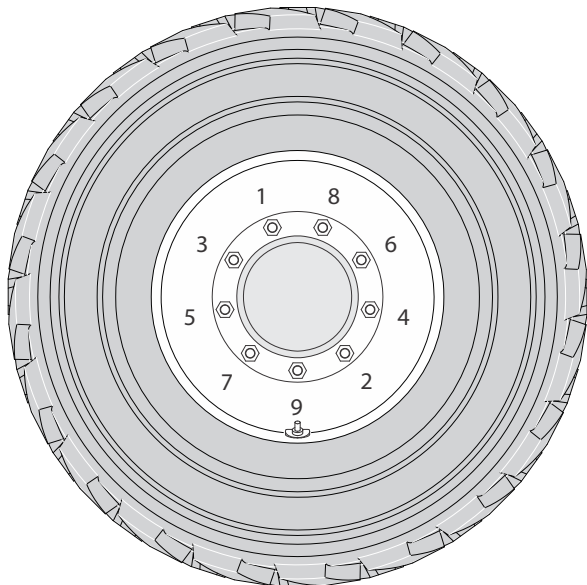

3. The tightening of the nuts should be done in stages. Following the recommended sequence, tighten nuts per wheel torque chart.

Table 6-20. Wheel Torque Chart

| TORQUE SEQUENCE | | |
|---------------------|-----------------------|-----------------------|
| 1st Stage | 2nd Stage | 3rd Stage |
| 40 ft-lb (55 Nm) | 100 ft-lb (130 Nm) | 170 ft-lb (255 Nm) |

4. Wheel nuts should be torqued after first 50 hours of operation and after each wheel removal. Check torque every 3 months or 150 hours of operation.

6.5 PROPANE FUEL FILTER REPLACEMENT

Removal

1. Relieve the propane fuel system pressure. Refer to Propane Fuel System Pressure Relief.
2. Disconnect the negative battery cable.
3. Slowly loosen the Filter housing and remove it.
4. Pull the filter housing from the Electric lock off assembly.
5. Remove the filter from the housing.
6. Locate Filter magnet and remove it.
7. Remove and discard the housing seal.
8. If equipped, remove and discard the retaining bolt seal.
9. Remove and discard mounting plate to lock off O-ring seal.

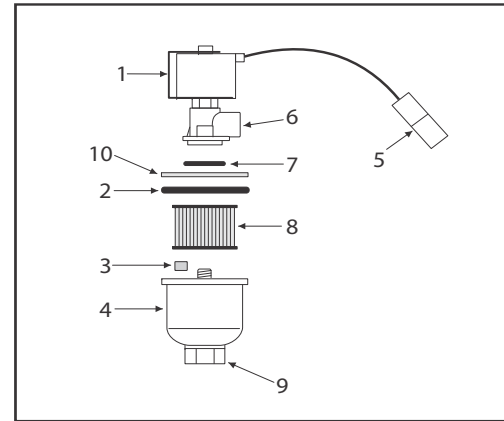

- | | |
|-------------------------------|----------------|
| 1. Electric Lock Off Solenoid | 6. Fuel Outlet |
| 2. Housing Seal | 7. O-ring |
| 3. Filter Magnet | 8. Filter |
| 4. Filter Housing | 9. Fuel Inlet |
| 5. Electrical Connector | 10. Ring |

Figure 6-12. Filter Lock Assembly

Installation

NOTICE

BE SURE TO REINSTALL THE FILTER MAGNET INTO THE HOUSING BEFORE INSTALLING NEW SEAL

1. Install the mounting plate to lock off O-ring seal.
2. If equipped, install the retaining bolt seal.
3. Install the housing seal.
4. Drop the magnet into the bottom of the filter housing.
5. Install the filter into the housing.
6. If equipped, install the retaining bolt into the filter housing.
7. Install the filter up to the bottom of the electric lock off.
8. Tighten the filter bowl retainer to 106 in-lb (12 Nm).
9. Open manual shut-off valve. Start the vehicle and leak check the propane fuel system at each serviced fitting. Refer to Propane Fuel System Leak Test.

6.6 PROPANE FUEL SYSTEM PRESSURE RELIEF

CAUTION

THE PROPANE FUEL SYSTEM OPERATES AT PRESSURES UP TO 312 PSI (21.5 BAR). TO MINIMIZE THE RISK OF FIRE AND PERSONAL INJURY, RELIEVE THE PROPANE FUEL SYSTEM PRESSURE (WHERE APPLICABLE) BEFORE SERVICING THE PROPANE FUEL SYSTEM COMPONENTS.

To relieve propane fuel system pressure:

1. Close the manual shut-off valve on the propane fuel tank.
2. Start and run the vehicle until the engine stalls.
3. Turn the ignition switch OFF.

CAUTION

RESIDUAL VAPOR PRESSURE WILL BE PRESENT IN THE FUEL SYSTEM. ENSURE THE WORK AREA IS WELL VENTILATED BEFORE DISCONNECTING ANY FUEL LINE.

6.7 SUPPLEMENTAL INFORMATION

The following information is provided in accordance with the requirements of the European Machinery Directive 2006/42/EC and is only applicable to CE machines.

For electric powered machines, the equivalent continuous A-Weighted sound pressure level at the work platform is less than 70dB(A)

For combustion engine powered machines, guaranteed Sound Power Level (LWA) per European Directive 2000/14/EC (Noise Emission in the Environment by Equipment for Use Outdoors) based on test methods in accordance with Annex III, Part B, Method 1 and 0 of the directive, is 104 dB.

The vibration total value to which the hand-arm system is subjected does not exceed 2,5 m/s². The highest root mean square value of weighted acceleration to which the whole body is subjected does not exceed 0,5 m/s².



An Oshkosh Corporation Company

TRANSFER OF OWNERSHIP

To Product Owner:

If you now own but ARE NOT the original purchaser of the product covered by this manual, we would like to know who you are. For the purpose of receiving safety-related bulletins, it is very important to keep JLG Industries, Inc. updated with the current ownership of all JLG products. JLG maintains owner information for each JLG product and uses this information in cases where owner notification is necessary.

Please use this form to provide JLG with updated information with regard to the current ownership of JLG products. Please return completed form to the JLG Product Safety & Reliability Department via facsimile or mail to address as specified below.

Thank You,
Product Safety & Reliability Department
JLG Industries, Inc.
13224 Fountainhead Plaza
Hagerstown, MD 21742
USA
Telephone: +1-717-485-6591
Fax: +1-301-745-3713

NOTE: Leased or rented units should not be included on this form.

Mfg. Model: _____

Serial Number: _____

Previous Owner: _____

Address: _____

Country: _____ Telephone: (____) _____

Date of Transfer: _____

Current Owner: _____

Address: _____

Country: _____ Telephone: (____) _____

Who in your organization should we notify?

Name: _____

Title: _____



WARNING:



The engine exhaust from this product contains chemicals known to the State of California to cause cancer, birth defects, or other reproductive harm.

1702961

PROPOSITION 65 WARNING

- **Battery posts, terminals and related accessories contain lead and lead compounds, chemicals known to the State of California to cause cancer and reproductive harm.**
- **Batteries also contain other chemicals known to the State of California to cause cancer.**
- **Wash hands after handling.**



An Oshkosh Corporation Company

Corporate Office
JLG Industries, Inc.
1 JLG Drive
McConnellsburg PA. 17233-9533
USA

(717) 485-5161

(717) 485-6417



3121289

JLG Worldwide Locations

JLG Industries (Australia)

P.O. Box 5119
11 Bolwarra Road
Port Macquarie
N.S.W. 2444
Australia

+61 2 65 811111

+61 2 65813058

JLG Latino Americana Ltda.

Rua Eng. Carlos Stevenson,
80-Suite 71
13092-310 Campinas-SP
Brazil

+55 19 3295 0407

+55 19 3295 1025

JLG Industries (UK) Ltd

Bentley House
Bentley Avenue
Middleton

Greater Manchester
M24 2GP - England

+44 (0)161 654 1000

+44 (0)161 654 1001

JLG France SAS

Z.I. de Baulieu
47400 Fauillet
France

+33 (0)5 53 88 31 70

+33 (0)5 53 88 31 79

JLG Deutschland GmbH

Max-Planck-Str. 21
D - 27721 Ritterhude - Ihlpohl
Germany

+49 (0)421 69 350 20

+49 (0)421 69 350 45

JLG Equipment Services Ltd.

Rm 1107 Landmark North
39 Lung Sum Avenue
Sheung Shui N. T.
Hong Kong

(852) 2639 5783

(852) 2639 5797

JLG Industries (Italia) s.r.l.

Via Po. 22
20010 Pregnana Milanese - MI
Italy

+39 029 359 5210

+39 029 359 5845

Oshkosh-JLG Singapore Technology

Equipment Pte Ltd
29 Tuas Ave 4,
Jurong Industrial Estate
Singapore, 639379

+65-6591 9030

+65-6591 9031

Plataformas Elevadoras
JLG Iberica, S.L.
Trapadella, 2
P.I. Castellbisbal Sur
08755 Castellbisbal, Barcelona
Spain

+34 93 772 4700

+34 93 771 1762

JLG Sverige AB
Enkopingsvagen 150
Box 704
SE - 176 27 Jarfalla
Sweden

+46 (0)850 659 500

+46 (0)850 659 534